

DOMINION EXECUTIVE COUNCIL

MINUTES

13 & 14 April 2019

Legion House - Dominion Command

Our Mission is to serve
Veterans, which includes
serving military and
RCMP members and
their families, to promote
remembrance and to
serve our communities
and our country.



**MINUTES OF THE DOMINION EXECUTIVE COUNCIL
13-14 APRIL 2019**

1.	OPENING	4
2:	GRAND PRESIDENT'S REMARKS.....	4
3:	DOMINION PRESIDENT'S REMARKS	4
4:	ADMINISTRATIVE ARRANGEMENTS.....	4
5.	APPROVAL OF MINUTES/ELECTRONIC DECISIONS.....	4
6:	DOMINION TREASURER'S REPORT	5
7:	THE ROYAL COMMONWEALTH EX-SERVICES LEAGUE	5
8:	COMMITTEE REPORTS	5
	a. Veterans, Services and Seniors Committee	5
	b. Poppy & Remembrance Committee	5
	c. Membership Committee	10
	d. Sports Committee.....	10
	e. Public Relations Committee	10
	f. Ritual & Awards Committee.....	11
	g. Constitution & Laws Committee	11
	h. RCEL Committee Report.....	11
	i. Dominion Convention Committee.....	12
	j. Defence & Security Committee	12
	k. Veterans Consultation Assembly.....	12
	l. Going Forward Committee	13
9:	CANVET PUBLICATIONS LTD.	14
10:	LEGION NATIONAL FOUNDATION.....	14
11:	NATIONAL EXECUTIVE DIRECTOR'S REPORT	15
12:	REMOVAL OF SIGNING AUTHORITIES	15
13:	LEGION POSITION PAPER	15
14:	COMMAND / SECTION REPORTS.....	15
	a. Tuberculous Veterans Section	15
	b. OSI Special Section	16
	c. BC/YT Command	16
	d. AB/NT Command	16
	e. SK Provincial Command	16
	f. MB & NWO Command	16
	g. ON Provincial Command.....	16
	h. QC Provincial Command.....	16
	i. NB Provincial Command	16
	j. NS/NU Command.....	17

MINUTES OF THE DOMINION EXECUTIVE COUNCIL
13-14 APRIL 2019

	k. PE Provincial Command	17
	l. NL Provincial Command.....	17
15:	SENIOR OFFICER REPORTS	17
16:	CHARTERS ISSUES AND CANCELLED	17
17:	DOMINION COMMAND BRANCHES.....	17
18:	REQUESTS FOR SUPPORT	17
19:	MEETINGS AND INVITATIONS	17
20:	CORRESPONDENCE	17
21:	NEW BUSINESS	18
22:	ADJOURNMENT	19

ATTENDEES:

Tom Irvine	Dominion President
Bruce Julian	Dominion First Vice President
Dave Flannigan	Immediate Past Dominion President
Angus Stanfield	Dominion Vice President
Brian Weaver	Dominion Vice President
Owen Parkhouse	Dominion Vice President
Bill Chafe	Dominion Chairman
Mark Barham	Dominion Treasurer
Larry Murray	Grand President
Michael Cook	BC/YT Command Trustee
Chris Strong	AB/NT Command President
Lorne Varga	SK Command President
Ronn Anderson	MB & NWO Command President
Sharon McKeown	ON Command President
Kenneth Ouellet	QC Command President
John Ladouceur	NB Command President
Melvin Crowe	NS/NU Command President
Stephen Gallant	PE Command President
Berkley Lawrence	NL Command President
Kandys Merola	TVS President
Chris Richardson	OSI Special Section President
Jill Carleton	OSI Special Section President-elect
Blaine Kiley	Vice-Chairman R & A Committee
Jim Rycroft	Chairman C & L Committee
Christopher Warren	Secretary General Royal Commonwealth Ex-Services League

STAFF IN ATTENDANCE:

Brad White	National Executive Director
Steven Clark	Director Corporate Services
Tim Murphy	Director Financial Services

MINUTES OF THE DOMINION EXECUTIVE COUNCIL
13-14 APRIL 2019

Ray McInnis	Director Veterans Services
Jennifer Morse	Canvet General Manager
Angela Keeling Colkitt	Executive Assistant
Kelly Therien	Executive Assistant
Bruce Rodger	Chief Technology Officer
Oksana Gorelova	Comptroller Designate
Tom McGregor	Legion Magazine

ANNEXES:

Annex "A"	Grand President's Remarks
Annex "B"	Dominion President's Remarks
Annex "C"	Administrative Arrangements
Annex "D"	Dominion Treasurer's Report & Statements
Annex "E"	RCEL Presentation
Annex "F"	Veterans, Services and Seniors Committee Report
Annex "G"	Poppy & Remembrance Committee Report
Annex "H"	Membership Committee Report
Annex "I"	Sports Committee Report
Annex "J"	Public Relations Committee Report
Annex "K"	Ritual & Awards Committee Report
Annex "L"	Constitution & Laws Committee Report
Annex "M"	RCEL Committee Report
Annex "N"	Dominion Convention Committee Report
Annex "O"	Defence & Security Committee Report
Annex "P"	Veterans Consultation Committee Report
Annex "Q"	Going Forward Committee Report
Annex "R"	Canvet Publications
Annex "S"	Legion National Foundation Report
Annex "T"	National Executive Director's Report
Annex "U"	Legion Position Paper
Annex "V"	Tuberculous Veterans Section Report
Annex "W"	OSI Special Section Report
Annex "X"	BC/YT Command Report
Annex "Y"	AB/NT Command Report
Annex "Z"	SK Provincial Command Report
Annex "AA"	MB & NWO Command Report
Annex "BB"	ON Provincial Command Report
Annex "CC"	QC Provincial Command Report
Annex "DD"	NB Provincial Command Report
Annex "EE"	NS/NU Command Report
Annex "FF"	PE Provincial Command Report
Annex "GG"	NL Provincial Command Report
Annex "HH"	Senior Officer Reports
Annex "II"	Charters Issued and Cancelled
Annex "JJ"	Dominion Command Branches

MINUTES OF THE DOMINION EXECUTIVE COUNCIL

13-14 APRIL 2019

Annex "KK"
Annex "LL"

Meetings and Invitation List
Other / New Business

1. OPENING

The Meeting of the Dominion Executive Council opened at 0900 hours on Saturday, 13 April 2019 in the Victory Boardroom of Legion House – National Headquarters.

2: GRAND PRESIDENT'S REMARKS

The Grand President presented remarks, attached at Annex "A".

3: DOMINION PRESIDENT'S REMARKS

The Dominion President presented remarks, attached at Annex "B".

4: ADMINISTRATIVE ARRANGEMENTS

The National Executive Director went over the administrative arrangements for this weekend's meeting. Presented as an information item only, attached at Annex "C".

5. APPROVAL OF MINUTES/ELECTRONIC DECISIONS

- a. The DEC last met on 25 November 2018. The minutes have been distributed electronically.

MOVED: It was moved that the DEC minutes of 25 November 2018 be approved.

CARRIED

- b. Review of Electronic Decisions/Email Voting

There was one Electronic / Email vote that took place since the last DEC meeting on 25 November 2018.

MOVED: It was moved that The Royal Canadian Legion sponsor the 2019 Army Cadet graduation reception and ceremony in relation to the Army Cadet Voyage in History in the amount of \$2000, to be sourced from the Dominion Command "Request for Support" budget.

CARRIED

MINUTES OF THE DOMINION EXECUTIVE COUNCIL
13-14 APRIL 2019

6: DOMINION TREASURER'S REPORT

The Dominion Treasurer presented his report, attached at Annex "D".

7: THE ROYAL COMMONWEALTH EX-SERVICES LEAGUE

Christopher Warren, Secretary General of the Royal Commonwealth Ex-Services League, briefed the Dominion Executive Council about the significant difference the UK Aid award will make to their operations specifically in the Caribbean and how it will allow the RCL and the RCEL to produce a way ahead for the next five years. He also discussed the Founder Members Conference to be held in Cape Town in February 2020 and ultimately the Centenary Conference in 2021. The RCL is critically important to RCEL and the future, not only in the run up to the Centenary Conference, but beyond. The presentation is attached at Annex "E"

MOVED: It was moved to accept the RCEL proposal and that \$25,000 be granted to the Royal Commonwealth Ex-Services League due to DFID funding as The Royal Canadian Legion portion has been increased to now support the non-DFID countries.

CARRIED

8: COMMITTEE REPORTS

a. Veterans, Services and Seniors Committee

The Veterans, Services and Seniors Committee report was presented, attached at Annex "F".

MOTION: It was moved that the Homeless Veterans Program Guidelines be approved and disseminated to Provincial Commands for assistance in developing a Leave the Streets Behind Program or to use to improve their already existing program.

CARRIED

**ACTION ALL ITEMS: Coordinator, VSS Committee
The report CARRIED**

b. Poppy & Remembrance Committee

The Poppy & Remembrance Committee report was presented, attached at Annex "G".

MINUTES OF THE DOMINION EXECUTIVE COUNCIL
13-14 APRIL 2019

MOTION: It was moved that the Legion National Foundation considering adding a Piper position to the Pilgrimage of Remembrance.

CARRIED

MOTION: It was moved that the Poppy & Remembrance Committee's Terms of Reference be modified to reflect the relationship between the committee and the Legion National Foundation by adding the following:

“On behalf of the Legion National Foundation, manage as well as propose motions or amendments to policy concerning:

- i. the parts of the Legion literary and poster remembrance contests for children and youth that are conducted at the national level;
- ii. revisions to the Legion Teaching Guide for Children and Youth; and
- iii. the Pilgrimage of Remembrance.”

CARRIED

MOTION: It was moved that the Legion adopt a formalized process to apply for the use of Poppy Trust Funds at the national level to include the guidelines, application, partnership agreement and final report.

CARRIED

MOTION: It was moved that \$30,000 be allocated from Poppy Funds to support the Poppy Drop initiative

CARRIED

MOTION: It was moved that \$30,000 be allocated from Poppy Funds to support the 2019 Digital Poppy marketing plan.

CARRIED

MOTION: It was moved that \$25,000 be allocated from Poppy Funds to support the work in 2019 of Heroes Mending on the Fly (formerly known as Project Healing Waters).

CARRIED

MINUTES OF THE DOMINION EXECUTIVE COUNCIL
13-14 APRIL 2019

MOTION: It was moved that \$90,000 be allocated from Poppy Funds to support the RCL Masters Scholarship for another three-year cycle, starting in 2020-2021 ending in 2022-2023.

CARRIED

MOTION: It was moved that \$25,000 be allocated from Poppy Funds to fund the Mefloquine research of The QUINISM Foundation.

CARRIED

MOTION: It was moved that \$300,000 be allocated from Poppy Funds to Project Trauma Support; \$100,000 on an annual basis for three years with the caveat that funding for years two and three will be contingent on receiving an annual accounting and report of expenditures prior to requesting ratification by DEC in years two and three.

CARRIED

MOTION: It was moved to create a national repository for Poppy Funds to allow branches to donate to authorized causes.

WITHDRAWN

MOTION AS AMENDED: It was moved that future Digital Poppy Funds be retained at Dominion Command as part of the national Poppy Fund with an option for use in local communities where a need exists for veteran support and local/provincial Poppy Funds are not adequate to support the request.

CARRIED

MOTION: It was moved that article 403.ii.d. of the Poppy Manual be revised to state: Veteran Services: (prior Provincial Command approval is required) 50 percent of the current balance, for support of Legion Branch drop-in centers or facilities that support Veterans services only as long as these provide known support to Veterans in the community.

CARRIED

MOTION: It was moved that article 402.vi.a. of the Poppy Manual be revised to state: the granting of bursaries to students who are Veterans, a lineal descendant or a collateral descendant (see definition section) of the

MINUTES OF THE DOMINION EXECUTIVE COUNCIL
13-14 APRIL 2019

eligible personnel as identified in Section 401 of this manual, who are in need of financial assistance. Bursaries may be awarded at any stage of a college or university program. The use of Poppy Trust Funds for Scholarships is NOT authorized.

WITHDRAWN

MOTION: It was moved that article 402.vi.d. of the Poppy Manual be revised to state: Poppy Funds can only be used for monetary awards for the top three placements in each category of the Poster and Literary contest and those awards not exceed those amounts given at the national level.

DEFEATED

MOTION: It was moved that article 403.ii.f. of the Poppy Manual be revised to state: Monuments: (prior Provincial Command approval is required) 25 percent of the current balance, for the purpose of constructing, maintaining or preserving local monuments to Veterans. The 25 percent must not exceed one-half of the total funds (50 percent) required to construct, maintain or preserve local monuments for which funds are allocated. For Legion-owned monuments, 50 percent of the current balance may be used for the purpose of constructing, maintaining or preserving the monument.

CARRIED

MOTION: It was moved that article 815.i. (Personal Tattoos) be removed from the Poppy Manual.

CARRIED

MOTION: It was moved that article 501.iv.f. of the Poppy Manual be revised to read: "general or non-specific donations to charities, registered or non-registered, or not-for-profits that do not meet the criteria listed in Sections 401, 402 or 403 of this manual. Examples include Heart and Stroke Foundation, Canadian Cancer Society, March of Dimes, non-Legion administered Food Banks, etc or for administrative or operational expenses of any organization. When in doubt, contact your provincial command for direction.

CARRIED

MINUTES OF THE DOMINION EXECUTIVE COUNCIL
13-14 APRIL 2019

MOTION: It was moved that article 403.ii.h. of the Poppy Manual be revised to read: Annual Veterans Visit: (prior Provincial Command approval is required) Up to \$25.00 per meal, per Veteran/spouse, to provide an annual visit to branches and/or when not feasible due to the age/condition of the veterans, to also host in a convenient location both for the Veterans and a spouse/caregiver who is accompanying a Veteran, or a Veteran's widower/widow accompanied by a caregiver to offer a meal and camaraderie. The amount is authorized from Poppy Trust Funds to cover the cost of the meal only and must not include the cost of any alcoholic beverages or other services, such as entertainment. Details of the event and receipts must be submitted after the event.

CARRIED

MOTION: It was moved that the Legion introduce a memorial symbol to recognize the sacrifices made by "Animals of War" with funds collected to be directed towards the recognition of the animal/veteran relationship.

DEFEATED

MOTION: It was moved that article 403.ii.f. of the Poppy Manual be revised to read: Monuments: (prior Provincial Command approval is required) 25 percent of the current balance, for the purpose of constructing, maintaining or preserving local monuments to Veterans. The 25 percent must not exceed one half of the total funds (50 percent) required to construct, maintain or preserve local monuments for which funds are allocated

WITHDRAWN

MOTION: It was moved to produce a formalized agreement to allow Urban Tactical to produce and distribute the Velcro Poppy.

DEFEATED

MOTION: It was moved that Dominion Command look into the development and distribution of a Velcro Poppy.

CARRIED

MINUTES OF THE DOMINION EXECUTIVE COUNCIL
13-14 APRIL 2019

MOTION: It was moved that appropriate action be taken against Urban Tactical to cease production and distribution of the Velcro Poppy due to trademark infringement.

CARRIED

MOTION: It was moved that the Poppy & Remembrance Committee be given the authority to proceed with a limited trial during the Poppy Campaign in 2019 using the Avrio cashless devices.

DEFEATED

**ACTION ALL ITEMS: Coordinator, Poppy & Remembrance
The report CARRIED**

c. Membership Committee

The Membership Committee report was presented, attached at Annex "H".

The report CARRIED

d. Sports Committee

The Sports Committee report was presented, attached at Annex "I".

MOTION: It was moved that section 707.b of the Sports Guide be amended to read: "Each Provincial Command must name one coach as the Head Coach and that *person has to be a fully certified National Coaching Certification Program (NCCP) club coach. All other team coaches require NCCP club coach trained certification.* There may be exceptions to this rule."

CARRIED

MOTION: It was moved that section 707.c of the Sports Guide be amended to read: "Each provincial athletic association is permitted to designate no more than two additional *NCCP club or sport trained coaches* to accompany their team *for professional development purposes.*"

CARRIED

**ACTION ALL ITEMS: Coordinator, Sports Committee
The report CARRIED**

e. Public Relations Committee

The Public Relations Committee report was presented, attached at Annex "J".

The report CARRIED

MINUTES OF THE DOMINION EXECUTIVE COUNCIL
13-14 APRIL 2019

f. Ritual & Awards Committee

The Ritual & Awards Committee report was presented, attached at Annex "K".

MOTION: It was moved that the D-Day 75th anniversary pin be allowed to be worn on Legion Dress and the uniforms of members of our Ladies Auxiliary on the right lapel below the We Support Our Troops pin until December 31, 2019.

CARRIED

**ACTION ITEMS: Coordinator, R & A Committee
The report CARRIED**

g. Constitution & Laws Committee

The Constitution & Laws Committee report was presented, attached at Annex "L".

MOTION: It was moved to insert the following as a preamble to GBL 226:
226. Provided there are no Article III proceedings pending:

CARRIED

MOTION: It was moved that GBL 311.a.i. be amended to read:
311.a.i. issue a reprimand that may also require a letter of apology to the Branch and/or if applicable, to the individual or individuals that may have been aggrieved.

CARRIED

MOTION: It was moved that GBL 311.a.iv. be amended to read:
311.a.iv. suspension, which includes removal from office (where applicable), for a period up to 12 months; and/or

CARRIED

**ACTION ALL ITEMS: Coordinator, C & L Committee
The report CARRIED**

h. RCEL Committee Report

The RCEL Committee report was presented, attached at Annex "M"

The report CARRIED

MINUTES OF THE DOMINION EXECUTIVE COUNCIL
13-14 APRIL 2019

i. Dominion Convention Committee

The Dominion Convention Committee report was presented, attached at Annex "N".

MOTION: It was moved that the convention registration fee for delegates and observers remain unchanged for the 2020 Dominion Convention.

CARRIED

MOTION: It was moved that the convention exhibitor fees remain unchanged for the 2020 Dominion Convention.

CARRIED

**ACTION ALL ITEMS: Coordinator, Dominion Convention
The report CARRIED**

j. Defence & Security Committee

The Defence & Security Committee report was presented, and is attached at Annex "O".

MOTION: It was moved that the latest version of the Letter of Understanding with the Conference of Defence Association (Version 5 dated 29 March 2019 – attached), once reviewed by the Constitution and Laws (C&L) Committee, be circulated to obtain signatures from the six signatories who are, for the RCL, the Dominion President, the Chair of the D&S Committee and the National Executive Director, and for the CDA and the CDA Institute, VAdm (ret) Rouleau, MGen (ret) Gosselin and the new Executive Director of both organizations, Dr. Youri Cormier.

IN ABEYANCE

**ACTION ALL ITEMS: Coordinator, D & S Committee
The report CARRIED**

k. Veterans Consultation Assembly

The Veterans Consultation Assembly report was presented, attached at Annex "P".

The report CARRIED

MINUTES OF THE DOMINION EXECUTIVE COUNCIL
13-14 APRIL 2019

I. Going Forward Committee

The Going Forward Committee report was presented, attached at Annex "Q".

MOTION: It was moved that DEC approve the Terms of Reference for the Going Forward Committee.

CARRIED

MOTION AS AMENDED: It was moved that DEC approve the national Stolen Valour policy as follows:

"Branches may become aware of suspected cases of Stolen Valour through a number of possible ways:

- From members,
- From Legion levels of authority who would in turn have found out through a member complaint or from Stolen Valour Canada (SVC),
- On line, through social media, report from the public, or the SVC website.

In any of these cases, it is important to respect our members' right to due process and to have their side heard. At the same time, fraudulent wearing of medals or uniforms is a federal crime, and branch executives are responsible to protect their branch's reputation and the reputation of The Royal Canadian Legion.

When made aware of suspected Stolen Valour, branch Presidents are to:

- Identify someone who can speak to the person accused of Stolen Valour. That individual can be the President themselves, or a trusted member of the branch who the person accused is comfortable talking to,
- Explain the accusation to the person, and explain the potential impact on the branch and the Legion if it were to be true.
- Give the person the opportunity to tell their side of the story. Ideally, the conversation will either clear up the situation by providing the President evidence that there is no case, or it will allow the person accused the opportunity to understand the potential harm they could cause and give

MINUTES OF THE DOMINION EXECUTIVE COUNCIL
13-14 APRIL 2019

them an opportunity to redeem themselves by removing those items that they were wearing fraudulently.

- Report to their Command headquarters through the appropriate channels how the issue has been resolved.

If the individual in question refuses to remove the decorations or medals and cannot provide a reasonable explanation as to their validity, a branch president has some options:

- They can notify law enforcement authorities of an alleged breach of Criminal Code S. 419,
- If any member believes that the alleged Stolen Valour constitutes conduct that brings or tends to bring the Legion into discredit, a complaint can be lodged under Article III of the General By-Laws. As per General By-Law 304.h, a branch President may deprive the member against whom the complaint is lodged of clubhouse privileges and remove them from office or position.

It is not recommended that the branch President officially engage with or solicit assistance from SVC; they are not an arm or resource of The Royal Canadian Legion and should not be treated as such. However, the member accused of Stolen Valour are to be made aware that SVC rarely lets an allegation go if they believe they have a case.

CARRIED

**ACTION ALL ITEMS: Coordinator, Going Forward Committee
The report CARRIED**

9: CANVET PUBLICATIONS LTD.

The Chairman of Canvet presented the report as an information item only, attached at Annex "R".

10: LEGION NATIONAL FOUNDATION

The Chairman of the Legion National Foundation presented the report as an information item, attached at Annex "S"

11: NATIONAL EXECUTIVE DIRECTOR'S REPORT

This report is for information only, attached at Annex "T"

12: REMOVAL OF SIGNING AUTHORITIES

Effective 17 May 2019 the following individuals are to be removed as signing authorities:

- a. Bradley K. White
- b. Timothy Murphy
- c. Peter Underhill

MOTION: It was moved that with the removal of these persons from the signing authority list, it is recommended that the following people be authorized as signing authorities

- a. Comptroller – Oksana Gorelova
- b. Deputy Director Corporate Services – Danny Martin
- c. Deputy Director Supply Management Services – Joan Elliott

CARRIED

13: LEGION POSITION PAPER

As is customary during the election period, Legion positions on issues related to the Purposes and Objects are publicized in a position paper format. That paper for this upcoming electoral period was distributed for review in early March. To date, no comments have been received.

The intent of this paper is to be distributed electronically to all sitting Members of Parliament, to the Canadian public and internally to all Legion members and is at Annex "U".

MOTION: It was moved that DEC approve the Legion Position Paper as circulated.

CARRIED

14: COMMAND / SECTION REPORTS

- a. Tuberculous Veterans Section

The President of the Tuberculous Veterans Section presented the report,

MINUTES OF THE DOMINION EXECUTIVE COUNCIL
13-14 APRIL 2019

attached at Annex "V".

The report CARRIED

b. OSI Special Section

The President of the OSI Special Section presented the report, attached at Annex "W".

The report CARRIED

c. BC/YT Command

The President of BC/YT Command presented the report as an information item only. There has been a change to the original report, which should state 58 units vs 48 units. This has been reflected on the report attached at Annex "X".

The report CARRIED

d. AB/NT Command

The President of AB/NT Command presented the report as an information item only, attached at Annex "Y".

The report CARRIED

e. SK Provincial Command

The President of SK Provincial Command presented the report as an information item only, attached at Annex "Z".

The report CARRIED

f. MB & NWO Command

The President of MB & NWO Command presented the report as an information item only, attached at Annex "AA".

The report CARRIED

g. ON Provincial Command

The President of ON Provincial Command presented the report as an information item only, attached at Annex "BB".

The report CARRIED

h. QC Provincial Command

The President of QC Provincial Command presented the report as an information item only, attached at Annex "CC".

The report CARRIED

i. NB Provincial Command

The President of NB Provincial Command presented the report as an information item only, attached at Annex "DD".

The report CARRIED

MINUTES OF THE DOMINION EXECUTIVE COUNCIL
13-14 APRIL 2019

j. NS/NU Command

The President of NS/NU Command presented the report as an information item only, attached at Annex "EE".

The report CARRIED

k. PE Provincial Command

The President of PE Provincial Command presented the report as an information item only, attached at Annex "FF".

The report CARRIED

l. NL Provincial Command

The President of NL Provincial Command presented the report as an information item only attached at Annex "GG".

The report CARRIED

15: SENIOR OFFICER REPORTS

Dominion Vice President Angus Stanfield updated the Dominion Executive Council on Cockrell House and Dominion President presented his report on the Aboriginal First Nations. These were presented as information items only and at Annex "HH"

16: CHARTERS ISSUES AND CANCELLED

This report was presented as an information item only, attached at Annex "II".

17: DOMINION COMMAND BRANCHES

This report was presented as an information item only, attached at Annex "JJ".

18: REQUESTS FOR SUPPORT

No requests for support have been received since the last DEC meeting of 25 November 2018.

19: MEETINGS AND INVITATIONS

This is an information item only, attached at Annex "KK"

20: CORRESPONDENCE

There has been no correspondence since the last DEC meeting of 25 November 2018.

MINUTES OF THE DOMINION EXECUTIVE COUNCIL
13-14 APRIL 2019

21: NEW BUSINESS

1. 75th Anniversary of the Liberation of the Netherlands. The Netherlands Ambassador to Canada, Henk van der Zwan, visited Legion House on 28 March 2019 to discuss possible partnerships to celebrate the 75th Anniversary of the Liberation of the Netherlands. The concept is to collaborate with the Canadian Tulip Festival to make tulip bulbs available this year for planting in the fall. Schools across Canada will be engaged to get youth and Veterans together to plant the bulbs. A copy of the presentation is attached at Annex "LL" as well as an overview of celebrations planned for 2020 in the Netherlands.

The Legion has partnered in the past with the Netherlands to commemorate previous anniversaries. What is being requested is that we endorse the program to our branches and that the branches become engaged locally to plant bulbs.

In addition, as the next Dominion Convention will be in 2020 and it coincides with the Liberation of the Netherlands, DEC is asked to consider inviting Prince Floris as our Guest of Honour for the convention in Saskatoon. Depending on his availability it may be appropriate to also invite the Netherlands Ambassador to Canada.

MOTION: It was moved that DEC endorse the program to our branches and that the branches become engaged locally to plant bulbs.

CARRIED

MOTION: It was moved that DEC invite Prince Floris as our Guest of Honour for the convention in Saskatoon. Depending on his availability it may be appropriate to also invite the Netherlands Ambassador to Canada.

CARRIED

2. Chris Strong from AB/NT Command discussed using better terms for Trusteeship; there were also discussions about the validity of The Royal Canadian Legion using petitions.
3. A Friends of the Legion presentation was shown to the DEC members from Owen Parkhouse and is attached at Annex "MM"
4. With reference to the RCEL presentation,

MOTION: It was moved that the RCEL presentation to DEC be added to the agenda of all upcoming provincial conventions.

MINUTES OF THE DOMINION EXECUTIVE COUNCIL
13-14 APRIL 2019

DEFEATED

5. Chris Richardson of the OSI Special Section discussed heraldry and the use in the Legion.

MOTION: It was moved that The Royal Canadian Legion apply for a coat of arms in time for our 100th anniversary.

TABLED

6. Leroy Washburn, Senior Technical Advisor to the Dominion Command Sports Committee passed away on April 13, 2019 at his home in Oromocto, NB. A condolence card was signed by the members of DEC along with a letter signed by the Dominion President.

Obituary is <http://www.oromoctofh.com/obituaries/133234>

7. Special Sections were given the power analogous to International Zone Commanders in GBL 137.g. However, an appeal provision was not referenced.

MOTION: It was moved to amend GBL 137.g by adding the following after the final statement: "Such action is subject to appeal to Dominion Command in like manner to the process specified in GBL 418.b."

CARRIED

22: ADJOURNMENT

The meeting of the Dominion Executive Council was adjourned Sunday, 14 April 2019 at 12:05 hrs.



National Executive Director

Dominion Chairman

GRAND PRESIDENT OPENING REMARKS TO DEC, 13 MARCH, 2019

THANK YOU COMRADE CHAIR.

GOOD MORNING, COMRADES.

AS ALWAYS, IT IS A PRIVILEGE AND A PLEASURE TO BE ABLE TO PARTICIPATE IN THIS IMPORTANT MEETING WITH ALL OF YOU.

I WILL KEEP MY COMMENTS FAIRLY BRIEF AND LARGELY RESTRICT MYSELF TO CONGRATULATING AND TO PASSING ON SOME WELL DESERVED "BRAVO ZULUS" AND THANK YOU TO SOME NOTABLE COMRADES.

HOWEVER BEFORE DOING THAT I DID WANT TO ADD ANOTHER ITEM TO YOUR "WHY THE LEGION MATTERS" LIST.

AS MOST OF YOU KNOW, THE LEGION HAS ACTIVELY SUPPORTED THE CANADIAN INSTITUTE OF MILITARY AND VETERANS HEALTH RESEARCH, OR CIMVHR, SINCE IT WAS ESTABLISHED NEARLY 10 YEARS AGO BY QUEEN'S UNIVERSITY AND RMC.

CIMVHR HAS NOW GROWN TO A MEMBERSHIP OF 44 UNIVERSITIES AND CONTRIBUTED GREATLY TO PRODUCING HIGH QUALITY, PEER REVIEWED, SCIENTIFIC RESEARCH IN MANY AREAS CRITICAL TO THE HEALTH AND WELL BEING OF SERVING MILITARY MEMBERS AS WELL AS VETERANS OF ALL AGES AND THEIR FAMILIES.

FOR THE PAST SEVERAL YEARS THE LEGION HAS SPONSORED CIMVHR SCHOLARSHIPS FOR MASTERS STUDENTS STUDYING IN AREAS RELATED TO VETERANS HEALTH RESEARCH AND HAS ALSO BEEN A SPONSOR FOR AND PARTICIPATED IN THE ANNUAL CIMVHR FORUM WHICH DRAWS HUNDREDS OF RESEARCHERS FROM CANADA AND ABROAD.

HOWEVER, THE CORE FUNDING TO ENSURE CONTINUED CIMVHR OPERATIONS WAS AT RISK OF RUNNING OUT THIS YEAR SO THE LEGION JOINED OTHERS IN ADVOCATING STRONGLY IN SUPPORT OF CIMVHR RESEARCH IN A NUMBER OF WAYS LEADING UP TO THE LAST BUDGET. THIS INCLUDED A LETTER FROM THE DOMINION PRESIDENT, COMRADE TOM, TO THE MINISTER OF FINANCE.

BUDGET 2019 STATED "THAT ORGANIZATIONS LIKE THE ROYAL CANADIAN LEGION THAT NEED TO DEVELOP EFFECTIVE EVIDENCE-BASED SERVICES FOR VETERANS AND THEIR FAMILIES RELY ON THE RESEARCH DONE BY CIMVHR".

THE BUDGET ALLOCATED \$25 MILLION OVER 10 YEARS TO FUND CIMVHR ONGOING OPERATIONS.

IN A SUBSEQUENT MESSAGE TO THE LEGION, DR. DAVID PEDLAR, THE SCIENTIFIC DIRECTOR OF CIMVHR WROTE: " WE ARE GRATEFUL FOR YOUR ONGOING COMMITMENT TO THE HEALTH AND WELL BEING OF OUR MILITARY, VETERANS AND THEIR FAMILIES. WE WOULD NOT HAVE BEEN ABLE TO REALIZE THIS TREMENDOUS SUCCESS, WITHOUT YOUR SUPPORT."

I PROVIDE THIS ANECDOTE SIMPLY AS YET ONE MORE INDICATOR THAT THE WORK OF THE LEGION TODAY REALLY DOES MATTER AND MUST CONTINUE.

IN THAT REGARD, AND ALTHOUGH WE ARE NOT OUT OF THE WOODS YET, IT HAS BEEN GREAT TO SEE THE ONGOING PRIORITY BEING ASSIGNED BY ALL OF YOU TO MEMBERSHIP. LIKE YOU I ALSO FIND THE DETAILED AND EXCELLENT WEEKLY UPDATES BY COMRADE RANDY USEFUL INFORMATION AND A REALLY HELPFUL REMINDER OF THIS CRITICAL PRIORITY. "BRAVO ZULU" AND MANY THANKS TO YOU AND YOUR FOLKS FOR ENABLING US TO KEEP OUR EYE ON THIS IMPORTANT BALL ON AN ONGOING BASIS, RANDY.

I WILL START MY 'THANK YOU'S' WITH THE PROVINCIAL COMMAND PRESIDENTS SINCE THIS WILL LIKELY BE YOUR FINAL DEC, AT LEAST IN IN YOUR CURRENT ROLE.

BRAVO ZULU AND THANKS TO EACH OF YOU FOR YOUR LEADERSHIP, YOUR DEDICATION AND YOUR KINDNESS. YOU "CARE" AND DURING YOUR "WATCH" I BELIEVE YOU HAVE MADE A BIG DIFFERENCE FOR VETERANS AND THEIR FAMILIES AND FOR THE FUTURE OF THE ROYAL CANADIAN LEGION. WE ARE STARTING TO SEE REAL PROGRESS IN A VARIETY OF AREAS INCLUDING MEMBERSHIP.

YOU ARE SPECIAL PEOPLE AND IT HAS BEEN A PRIVILEGE AND A PLEASURE TO WORK WITH YOU THROUGHOUT THE PAST TWO YEARS AND, IN COMRADE CHRIS'S CASE THE PAST FOUR YEARS. THANKS FOR EVERYTHING, TAKE CARE OF YOURSELVES AND ALL THE VERY BEST TO ALL OF YOU, WHEREVER LIFE AND YOUR INVOLVEMENT IN THE LEGION MAY LEAD.

I WOULD ALSO LIKE THANK COMRADE RICHARD BLANCHETTE WHO HAS STEPPED DOWN AS CHAIR OF THE DEFENCE AND SECURITY COMMITTEE AFTER FOUR AND A HALF YEARS. I WILL FORWARD THE FOLLOWING MESSAGE TO HIM FOLOWING DEC:

FELICITATIONS ET MERCI DU FOND DU COEUR POUR UN TRAVAIL SUPERBE COMME PRESIDENT DE LA COMITE DE LA DEFENCE ET SECURITE, RICHARD. DANS LA LANGUE DE LA MARINE , JE DOIS TE DONNER UN GRAND BRAVO ZULU POUR TON LEADERSHIP FORT ET TON EFFORT TOUJOURS EXCELLENT. MERCI ENCORE MON AMI!

MANY THANKS AND A BIG BRAVO ZULU AS WELL TO COMRADE CHRIS RICHARDSON FOR YOUR LEADERSHIP, DEDICATION AND THOUGHTFUL AND FORTHRIGHT INSIGHT "AT THE HELM" OF THE OSI SPECIAL SECTION AND AS A MEMBER OF DEC. TAKE CARE OF YOURSELF AND ALL THE BEST, CHRIS!

FURTHER, I WOULD LIKE TO EXTEND MY PERSONAL CONGRATULATIONS AND A WARM WELCOME TO COMRADE JILL CARLETON WHO WILL BE REPLACING CHRIS AS PRESIDENT OF THE OSI SPECIAL SECTION ON 17 APRIL. YOU HAVE IMPRESSIVE QUALIFICATIONS FOR THIS CHALLENGING AND IMPORTANT LEADERSHIP ROLE, JILL, AND I WISH YOU EVERY POSSIBLE SUCCESS AND FULFILLMENT IN IT.

COMRADE TIM MURPHY ALSO MERITS A BIG BRAVO ZULU AND HEARTFELT THANKS AND CONGRATULATIONS AS HE RETIRES FOLLOWING MANY YEARS OF DISTINGUISHED SERVICE TO THE ROYAL CANADIAN LEGION. ALTHOUGH YOU WILL BE SADLY MISSED, TIM, YOUR FINE LEGACY OF QUIET PROFESSIONALISM, SELFLESS DEDICATION, INTEGRITY, AND HUMILITY AS WELL AS AN ALWAYS KIND AND GENEROUS CONCERN FOR OTHERS, WILL ENDURE IN THE STERLING EXAMPLE THAT YOU SET FOR THE REST OF US. TAKE CARE OF YOURSELF AND ALL THE VERY BEST FOR THE FUTURE, TIM.

DEC IS ALSO BIDDING FAREWELL TO OUR OUTSTANDING DIRECTOR CORPORATE SERVICES FOR THE PAST SEVERAL YEARS, COMRADE STEVEN CLARK. HAPPILY HOWEVER, STEVEN IS REMAINING WITH DOMINION COMMAND AS OUR NEW NATIONAL EXECUTIVE DIRECTOR. A BIG BRAVO ZULU AND

CONGRATULATIONS ON THIS WELL DESERVED PROMOTION. IT IS TERRIFIC TO SEE DEMONSTRATED LEADERSHIP, EXCEPTIONAL TALENT AND SELFLESS DEDICATION PUT TO OPTIMUM USE BY THE LEGION, PARTICULARLY AT A TIME OF SIGNIFICANT CHALLENGE AND TREMENDOUS OPPORTUNITY FOR THIS GREAT NATIONAL INSTITUTION. TAKE CARE OF YOURSELF AND BEST WISHES FOR EVERY POSSIBLE SUCCESS AND FULFILLMENT "AT THE HELM" OF LEGION HOUSE, STEVEN.

LAST BUT CERTAINLY NOT LEAST WE ARE BIDDING FAREWELL TO OUR NATIONAL EXECUTIVE DIRECTOR FOR THE PAST DECADE. ALTHOUGH MUCH WAS SAID YESTERDAY AT THE SPECIAL RECEPTION IN HIS HONOUR, I COULD NOT LET BRAD ESCAPE WITHOUT ALSO EXPRESSING HEARTFELT THANKS AND A BIG BRAVO ZULU DURING HIS FINAL DEC IN THIS ROLE.

AS I STATED TO BRAD IN AN E MAIL SHORTLY AFTER LEARNING OF HIS PENDING RETIREMENT:

"YOU ARE A LIVING EXAMPLE OF 'SERVICE BEFORE SELF' AND ALTHOUGH YOU WILL BE SADLY MISSED AT DOMINION COMMAND AND BY THE NATIONAL VETERANS COMMUNITY, YOU HAVE BUILT A STRONG AND CAPABLE LEGION HOUSE 'TEAM' AND YOUR PERSONAL LEGACY OF REMARKABLE DEDICATION TO THE AIMS AND OBJECTIVES OF THE LEGION; WISE, FORTHRIGHT COUNSEL AND SUPERB LOYAL SUPPORT TO ITS SENIOR ELECTED LEADERSHIP WILL ENDURE IN THE MANY LIVES YOU HAVE TOUCHED THROUGH YOUR THOUGHTFUL MENTORSHIP AND STERLING EXAMPLE.....ALL THE VERY BEST TO YOU, THERESE AND YOUR FAMILY FOR A FUTURE BLESSED "WITH FAIR WINDS AND FOLLOWING SEAS" WHEREVER LIFE MAY LEAD. TAKE CARE OF YOURSELF AND PLEASE STAY IN TOUCH."

THANKS AGAIN FOR EVERYTHING, BRAD AND THANK YOU, COMRADES, THAT CONCLUDES MY OPENING REMARKS.

Good Morning Comrades...

Welcome to you all! As usual I'm looking forward to our time here in Ottawa.

I'm going to keep my remarks short today, and I want to begin with a few changes related to our Committees.

First, I'd like to announce that Dave Flannigan will be taking on a new role as part of our Membership Committee. He will bring great perspective to this role and we're looking forward to his ideas.

In addition, our new Centennial Committee will be chaired by Owen Parkhouse and Brad has agreed to be on the committee. The committee will expand as necessary in the future. It's important to me that we get started thinking about the Legion's 100-year anniversary in 2026, and that we begin the planning well in advance.

Speaking of our committees, I have a serious request.

I ask that as Chairs of our various committees, you remember to focus upon membership. I expect all of you to discuss membership at each meeting, and what actions you're taking to support it. Whether it has to do with recruitment, retention, or reinstatement – we're all part of the solution. I would also like to see what you discuss, reflected in your committee meeting notes.

Just last week, I traveled to British Columbia with Steven to join their Provincial Executive Council and learn about how things are going in that province. I met with SEOs and attended their PEC meeting. I was pleased with what I heard and can tell you I'll be looking at removing the Trusteeship there in the near future if things continue along the same path.

It's no secret that Stolen Valour is something I will continue to focus upon during my term. I take every opportunity I can to bring it up. Like now.

I hope that all of you see how important this is – that we cannot allow people who make false claims about their service, or those who wear unearned medals, to represent the Legion. To that end, I'm asking you to think about additional ways to ensure such people do not become members in the first place, and if they do, that they are quickly identified and shown the door.

On to something positive – I want to tell you about a project called "Vet Build." It's a special project run by a special person named Craig Hood.

This project entails having veterans get together, to build models. Simple concept but great healing potential. The group held its first meeting in Ajax, Ontario recently and the feedback was amazing. The Legion is very supportive of these sorts of initiatives, and will

be invited to attend and take pictures at a follow-up session this spring or summer. It's an idea that has all the makings of a national initiative down the line. I'll keep you posted.

I'd like to remind you of something I said last fall. I want to continue hearing from you. For you to share your honest feelings and ideas. That means speaking up when you have thoughts about how to tweak my vision. What's working, and what's not. We really have to do this together, to serve out veterans, families and communities.

Finally, I'd like to say a special thank you to Richard Blanchette, who has stepped down as Chair of our Defense and Security committee, and Chris Richardson, who will be stepping down as President of our OSI Special Section. They leave us with a solid foundation and that will put us in good shape moving forward.

Thanks again to Brad, who leaves us in May after many years of dedicated service, and to Steven, to whom the torch is being passed. I'd also like to thank all Provincial Presidents for their service over the past two years.

Looking forward to our discussions, thanks for being here.

ITEM 4: ADMINISTRATIVE ARRANGEMENTS

a. Schedule – Saturday, 13 April 2019

- i. 0900 hours – DEC convenes
- ii. 1200 hours - Lunch at Dominion Command (Call of the Chairman)
- iii. 1315 hours – DEC convenes in main boardroom
- iv. 1600 hours – DEC adjourns for the day (Call of the Chairman)
- v. The Secretary General of the Commonwealth Ex-Services League, Christopher Warren, will address DEC sometime in the morning as he will be returning to the UK in the late afternoon.

b. Schedule – Sunday, 14 April 2019

- vi. 0900 hours – DEC convenes
- vii. 1200 hours - Lunch at Dominion Command (Call of the Chairman)
- viii. 1315 hours – DEC convenes in main boardroom
- ix. 1600 hours – DEC adjourns for the day (Call of the Chairman)

c. Meals. Lunch will be provided on both days. Members' per diem claims will be adjusted accordingly.

d. Local Map. A map of the local area is attached for your convenience.

e. Hotel Reservations. Your reservations have been made according to the DEC and Committee meeting schedule. If you intend to check out earlier, please advise the hotel as soon as possible. Please take note that DEC members are responsible to pay their hotel bill at check out and then reclaim on their expense claim forms.

f. Reports. Reports will not be read verbatim but rather with a view to review them and then only address issues that are raised or the recommendations presented for approval. All meeting material is provided electronically and will not be reproduced in paper format.

g. Smoking. Ottawa City By-Laws do not permit smoking in any office building including bars and restaurants. However, the Director Corporate Services will provide one of the smokers with a door pass to enable smokers to use the rear entrance to permit smoking outside during the break periods. Smoking is only permitted at the rear of the building.

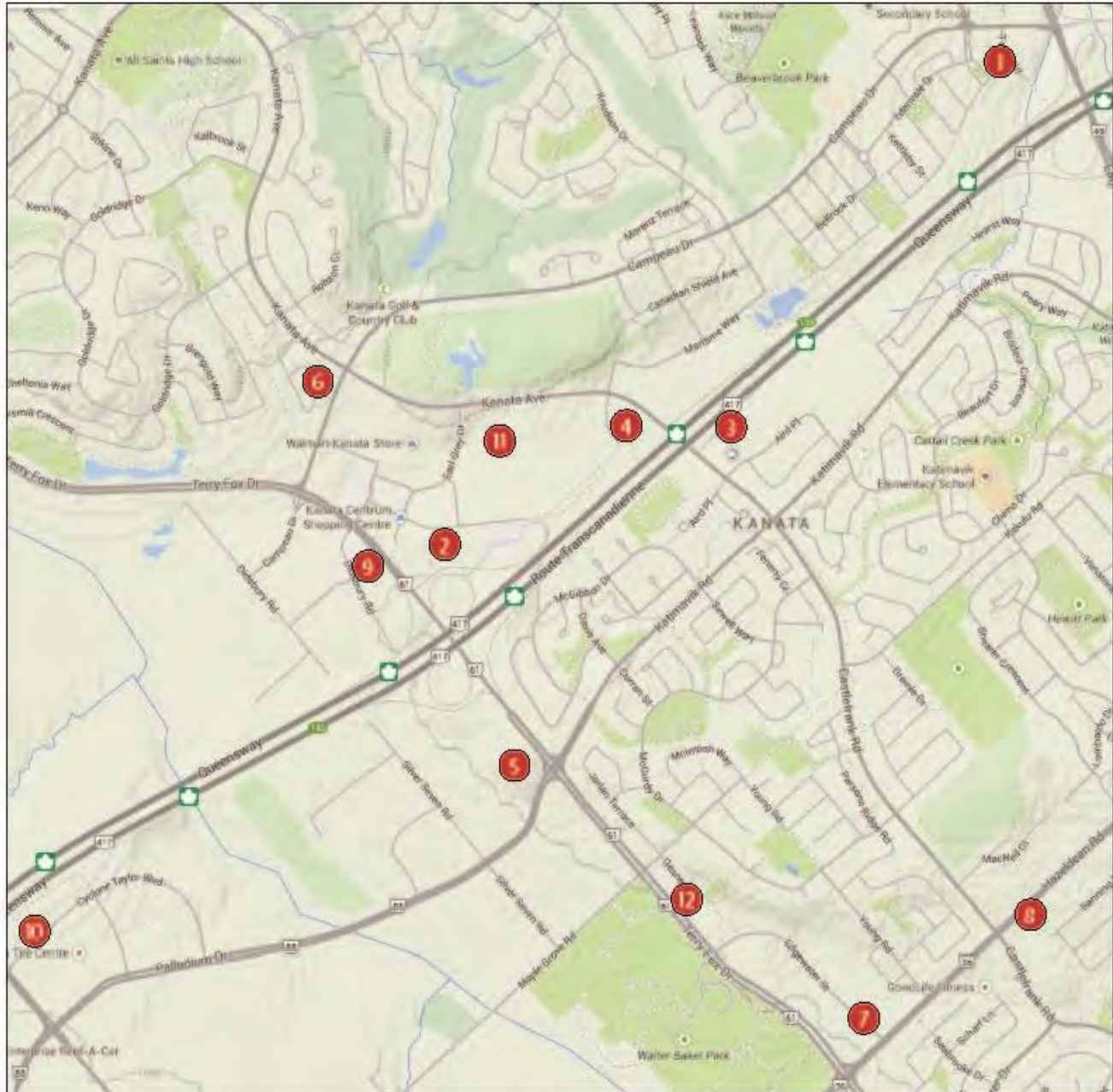

1. LaPointe Seafood Restaurant
2. Centrum Area
 - numerous restaurants
 - shopping facilities
 - movie theatre
3. Legion House
4. Holiday Inn Select Hotel
5. Country Inn Suites Hotel

6. Liquor Control Board of Ontario (LCBO)
7. Wendy's, Tim Horton's
8. Pizza Hut, Burger King
9. Dairy Queen, Italian Restaurant
10. Canadian Tire Place—Hockey arena
11. Walmart
12. Darcy McGee's, East Side Mario's,
A & W, Swiss Chalet

ITEM 6: DOMINION TREASURER'S REPORT

I. OVERVIEW OF 2018 YEAR

The 2018 year finished well, achieving a surplus of \$294,665. This was an improvement of \$240,906 over the budgeted surplus of \$53,759. Revenues bettered the budget by 6%. Expenses exceeded budget by 3.8%.

On the revenue side, the membership decline was less than budgeted. A total of \$6,045,320 was collected \$116,474 more than budgeted. Interest and dividends earned on investments finished strongly reaching \$594,945 8% more than budget. The Supply Department had a strong fourth quarter and finished the year with \$2,385,073, surpassing the budget expectation by \$285,073. Miscellaneous revenue provided an additional boost of \$50,352.

Total expenses came 3.8% over budget. Other program expenses were up significantly totaling \$315,008 (Legal), as were the expenses for Legion House, up 34.9% (repairs and maintenance). Supply Chain Management expenses were over budget by 14.1% (cost of goods sold). Membership exceeded budget by 9.4% (Pack out and permanent membership cards). Committees finished 25.3% below budget, a reduction of \$242,259. All other Departments/Sections finished close to the budget amounts.

II. ANALYSIS

As mentioned, we have had a good year generating revenue. Membership and Supply Chain Management sales revenue have exceeded expectations. Investments had a good fourth quarter and surpassed the budget by \$46,445. Supply Chain Management finished the year strongly. The Departments fourth quarter sales were up by 36% over the 2017 Quarter four sales. This pushed the year-end total up.

On the expense side:

I. Departments/Sections

- Membership Section – \$51,493: Postage (\$21,939), pack out (\$6,123) and permanent membership cards (\$20,594) were over budget. This was offset by reductions Memberships forms, paper (\$10,000), office supplies, and credit card processing (\$2,635).
- Supply Chain Management – \$239,200: With the total sales exceeding budget, the cost of goods sold increased correspondingly (\$145,605 product, \$15,026

shipping. Personnel cost increased for more warehouse assistance and costs related to a staff departure (\$80,706).

- Other Program expenses - \$152,508: Legal expenses were \$167,634 over budget. This was offset by reductions in Requests for Support (\$8,000), translation (\$9,094). Outside of the usual legal costs, legal expenses were high due to staffing issues and company law and governance issues.
- Legion House - \$121,162: Underwent major repairs for the building foundation \$91,053, cracked pipe in elevator shaft \$10,178. As well as, repair and replacement of lights \$9,440.

II. Committees

Committees have come under budget by \$242,259. The significant items are:

- VSS - \$15,356: savings on travel \$7.4K as meeting held by teleconference and the Homeless Summit was not held this year which saved \$5K.
- Public Relations - \$26,931: reduction in travel \$20K and specialist consulting were under budget by \$9K.
- Sports - \$37,655: Participation Sports travel \$11K, Track & Field recoveries \$35K less Committee travel over budget by \$7.8K.
- Going Forward Committee - \$40,998: travel was higher by \$9K as there were two meetings and the budget was set for one meeting. This is offset by \$50K that was allotted for specialist consulting that was never used.
- Elected Officers - \$52,497: President's budget was underspent by \$44K, Elected Officers travel was under budget by \$8K.
- Convention - \$52,195: A grant was received from Winnipeg Tourism for \$50.6K.

III. BUDGET VERSUS ACTUAL CHARTS

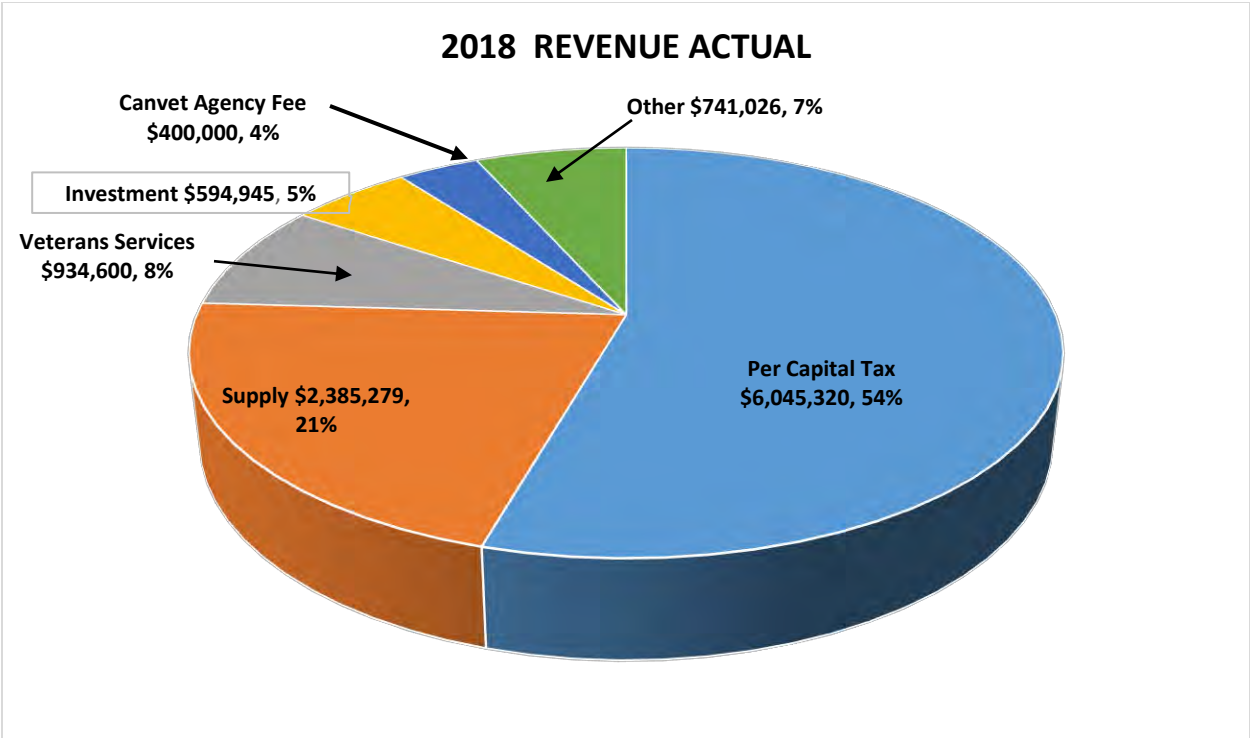
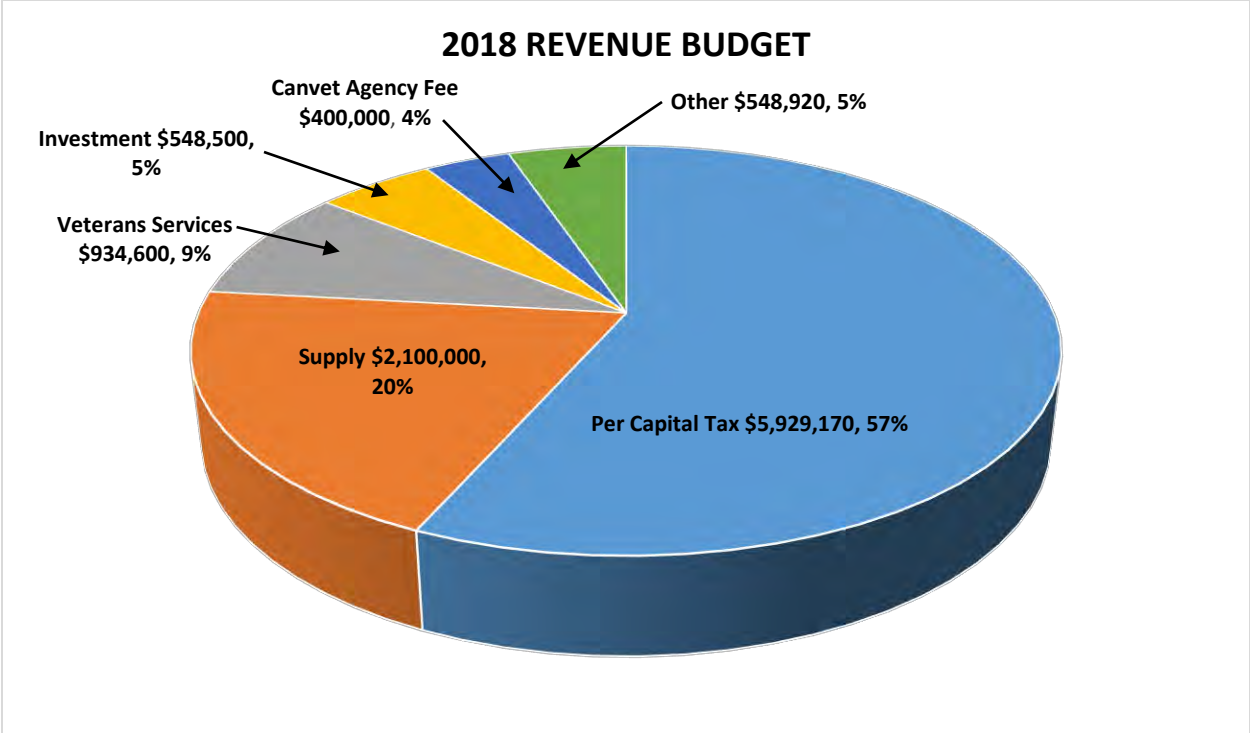

2018 EXPENSE BUDGET

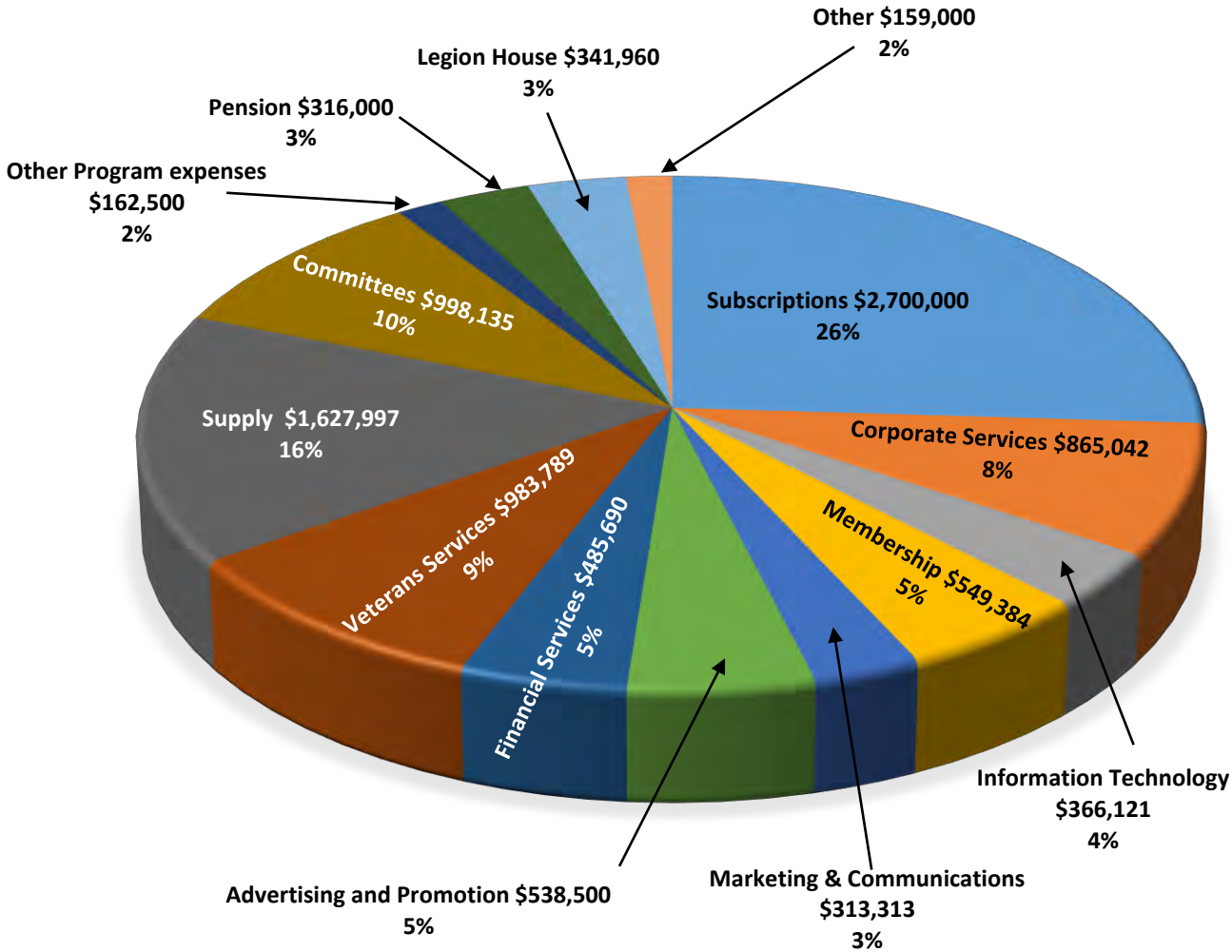

2018 EXPENSE ACTUALS

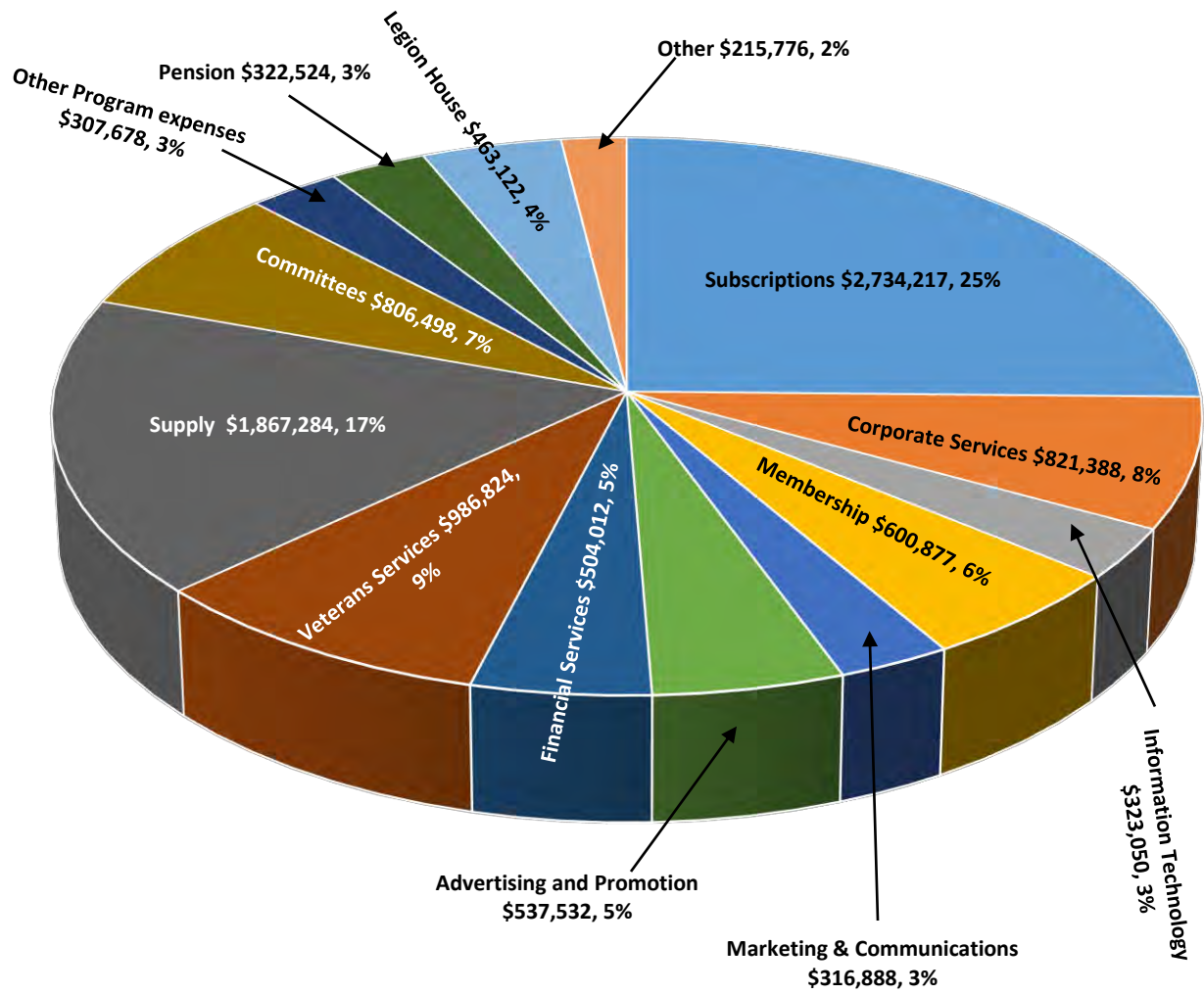

IV. 2018 GENERAL FUND STATEMENTS OF REVENUE AND EXPENSE

The Financial Statements are attached for information. I am now prepared to answer any questions you may have concerning these.



ALL CANADIAN LEGION-DOMINION COMMAND
GENERAL FUNDS

Statement of Revenue and Expense

	Dec 2017 ACTUAL	2017 ACTUAL	Dec 2018 ACTUAL	2018 FORECAST	2018 BUDGET	2019 BUDGET
REVENUE						
Per Capita Tax	5,883,846	5,883,846	6,045,320	5,929,170	5,929,170	5,766,000
Canvet						
- Agency Fee & Support	400,000	400,000	400,000	400,000	400,000	400,000
Investment Income	590,112	590,112	594,945	548,500	548,500	510,000
Veterans Services Poppy Fund	735,000	735,000	934,600	934,600	934,600	989,045
Veterans Visitation	193,080	193,080	141,960	128,000	0	100,000
Supply Chain Management	2,693,279	2,693,279	2,385,073	2,060,000	2,100,000	2,250,000
Legion House						
- Tenants	82,920	82,920	82,920	82,920	82,920	82,920
- Internal	316,000	316,000	316,000	316,000	316,000	316,000
Miscellaneous						
- Master Card	85,112	85,112	70,385	60,000	60,000	60,000
- Other	197,864	197,864	129,967	90,000	90,000	116,000
Estate Bequest	4,443	4,443	0	0	0	0
TOTAL REVENUE	11,181,656	11,181,656	11,101,170	10,549,190	10,461,190	10,589,965
EXPENSE						
Legion Magazine Subscriptions	2,756,273	2,756,273	2,734,217	2,700,000	2,700,000	2,630,000
Corporate Services	833,600	833,600	821,388	862,042	865,042	843,000
Information Technology	350,915	350,915	365,264	351,471	366,121	375,850
Membership	689,655	689,655	600,877	575,115	549,384	601,634
Marketing & Communications	337,656	337,656	316,888	313,313	313,313	326,100
Marketing, Advertising, Promoti	425,547	425,547	537,532	539,000	538,500	538,500
Financial Services	493,654	493,654	504,012	483,829	485,690	461,050
Veterans Services	874,678	874,678	986,824	983,789	983,789	1,040,900
Veterans Visitation	137,472	137,472	103,633	95,000	0	74,000
Supply Chain Management	1,935,659	1,935,659	1,867,197	1,660,194	1,627,997	1,729,400
Committees	873,683	873,683	755,876	928,525	998,135	1,007,875
Other Program Expenses	216,874	216,874	315,008	162,500	162,500	129,000
Amortization	108,990	108,990	112,143	112,000	123,000	112,000
Employer Pension Contribution	337,759	337,759	322,524	316,000	316,000	325,000
Legion House	343,263	343,263	463,122	355,860	341,960	344,400
Canvet Interest Expense	0	0	0	0	36,000	0
TOTAL EXPENSE	10,715,678	10,715,678	10,806,505	10,438,638	10,407,431	10,538,709
NET INCOME (LOSS) FROM O	465,978	465,978	294,665	110,552	53,759	51,256

THE ROYAL CANADIAN LEGION - DOMINION COMMAND
GENERAL FUNDS

Corporate Services

	Dec 2017 ACTUAL	2017 ACTUAL	Dec 2018 ACTUAL	2018 FORECAST	2018 BUDGET	2019 BUDGET
EXPENSE						
Salaries	737,167	737,167	720,274	766,416	766,416	747,000
Retirement Allowance	16,977	16,977	15,712	15,021	15,021	15,000
Other Benefits	67,298	67,298	62,001	65,905	65,905	66,000
Temporary & Contract Staff	0	0	10,401	0	0	0
TOTAL PERSONNEL	821,442	821,442	808,388	847,342	847,342	828,000
Office Supplies	52,273	52,273	46,467	45,000	45,000	45,000
Telephone	15,377	15,377	14,321	16,000	16,000	16,000
Postage, Express	10,346	10,346	10,065	10,000	10,000	10,000
Printing, Stationery	4,089	4,089	7,661	8,000	8,000	6,000
Staff Travel	883	883	426	1,000	1,000	1,000
Insurance	18,220	18,220	17,828	20,400	20,400	21,000
Rent (CR to Building)	108,000	108,000	108,000	108,000	108,000	108,000
Staff Recruitment	878	878	179	1,000	2,000	2,000
Computer Network Support	3,000	3,000	3,500	3,500	3,500	3,500
Miscellaneous	1,704	1,704	7,948	2,500	2,500	2,500
Training	6,089	6,089	5,306	8,000	10,000	10,000
TOTAL EXPENSE	1,042,301	1,042,301	1,030,089	1,070,742	1,073,742	1,053,000
Less: charged to:						
Membership	15,000	15,000	15,000	15,000	15,000	15,000
Marketing and Communications	15,000	15,000	15,000	15,000	15,000	15,000
Service Bureau	30,000	30,000	30,000	30,000	30,000	30,000
Poppy Fund	148,700	148,700	148,700	148,700	148,700	150,000
	208,700	208,700	208,700	208,700	208,700	210,000
NET EXPENSE	833,601	833,601	821,389	862,042	865,042	843,000

THE ROYAL CANADIAN LEGION-DOMINION COMMAND
GENERAL FUNDS

INFORMATION TECHNOLOGY SECTION

	Dec 2017 ACTUAL	2017 ACTUAL	Dec 2018 ACTUAL	2018 FORECAST	2018 BUDGET	2019 BUDGET
EXPENSE						
Salaries	169,994	169,994	216,313	177,257	177,257	183,000
Retirement Allowance	3,510	3,510	3,896	3,665	3,665	3,800
Other Benefits	19,009	19,009	20,678	21,949	21,949	21,300
Contract	39,497	39,497	51,962	49,000	49,000	51,000
TOTAL PERSONNEL	232,010	232,010	292,849	251,871	251,871	259,100
Office Supplies	0	0	0	0	50	50
Telephone	5,473	5,473	6,038	6,000	6,000	6,000
Postage, Express	190	190	0	50	50	50
Printing, Stationery	1	1	0	0	50	50
Rent (CR to Building)	10,000	10,000	10,000	10,000	10,000	10,000
Miscellaneous	60	60	40	50	100	100
Network & PC						
- Maintenance Contracts/Lease	83,353	83,353	60,820	95,000	95,000	95,000
- Programming & Support	24,667	24,667	16,333	10,000	25,000	25,000
- Supplies & Other	12,867	12,867	12,690	12,000	12,000	12,000
- Website & Internet connectivity & support	6,294	6,294	6,494	6,000	6,000	8,000
TOTAL EXPENSE	374,915	374,915	405,264	390,971	406,121	415,350
Less: charged to:						
Administration	3,000	3,000	3,500	3,500	3,500	3,500
Finance	3,000	3,000	7,500	7,500	7,500	7,500
Membership	5,000	5,000	7,500	7,500	7,500	7,500
Marketing	1,000	1,000	2,500	2,500	2,500	2,500
Service Bureau	3,000	3,000	4,500	4,500	4,500	4,500
Supply	6,000	6,000	7,500	7,000	7,500	7,000
Canvet	3,000	3,000	5,000	5,000	5,000	5,000
IT	0	0	2,000	2,000	2,000	2,000
	24,000	24,000	40,000	39,500	40,000	39,500
NET EXPENSE	350,915	350,915	365,264	351,471	366,121	375,850

THE ROYAL CANADIAN LEGION-DOMINION COMMAND
GENERAL FUNDS

Membership Section

	Dec 2017 ACTUAL	2017 ACTUAL	Dec 2018 ACTUAL	2018 FORECAST	2018 BUDGET	2019 BUDGET
REVENUE						
Agency Fee	400,000	400,000	400,000	400,000	400,000	400,000
TOTAL REVENUE	400,000	400,000	400,000	400,000	400,000	400,000
EXPENSE						
Salaries	239,980	239,980	238,978	239,934	239,934	247,000
Retirement Allowance	4,950	4,950	5,333	4,858	4,858	5,000
Other Benefits	38,112	38,112	38,276	37,923	37,923	39,000
Temporary & Contract Staff	106,634	106,634	106,857	110,000	103,769	108,434
TOTAL PERSONNEL	389,676	389,676	389,444	392,715	386,484	399,434
Office Supplies	674	674	378	1,400	1,400	1,200
Telephone	8,659	8,659	10,993	8,000	8,000	8,000
Postage, Express	46,445	46,445	57,939	36,000	36,000	36,000
Printing, Stationery	9,889	9,889	8,064	7,000	3,500	7,000
Rent (CR to Building)	54,000	54,000	54,000	54,000	54,000	54,000
Miscellaneous	3,418	3,418	7,455	2,500	2,500	2,500
Computer Network Support	5,000	5,000	7,500	7,500	7,500	7,500
Administrative Support	15,000	15,000	15,000	15,000	15,000	15,000
Permanent membership cards	100,784	100,784	20,594	15,000	0	15,000
Membership cards, forms and p	18,515	18,515	0	1,000	10,000	1,000
Membership Pack out	31,270	31,270	6,123	10,000	0	30,000
Credit Card Processing Fees	6,324	6,324	23,387	25,000	25,000	25,000
TOTAL EXPENSE	689,654	689,654	600,877	575,115	549,384	601,634
NET EXPENSE	289,654	289,654	200,877	175,115	149,384	201,634

THE ROYAL CANADIAN LEGION-DOMINION COMMAND
 GENERAL FUNDS

Marketing Section

EXPENSE	Dec		Dec			
	2017	2017	2018	2018	2018	2019
	ACTUAL	ACTUAL	ACTUAL	FORECAST	BUDGET	BUDGET
Salaries	284,392	284,392	254,958	253,053	253,053	265,000
Retirement Allowance	4,104	4,104	5,690	5,115	5,115	5,300
Other Benefits	18,405	18,405	22,332	22,145	22,145	23,000
TOTAL PERSONNEL	306,901	306,901	282,980	280,313	280,313	293,300
Office Supplies	0	0	131	400	400	200
Telephone	2,376	2,376	3,183	1,800	1,800	1,800
Postage, Express	1	1	1,157	100	100	100
Printing, Stationery	62	62	713	200	200	200
Staff Travel	33	33	0	500	500	500
Rent (CR to Building)	10,000	10,000	10,000	10,000	10,000	10,000
Miscellaneous	2,282	2,282	1,224	2,500	2,500	2,500
Computer Network Support	1,000	1,000	2,500	2,500	2,500	2,500
Administrative Support	15,000	15,000	15,000	15,000	15,000	15,000
TOTAL EXPENSE	337,655	337,655	316,888	313,313	313,313	326,100

THE ROYAL CANADIAN LEGION-DOMINION COMMAND
GENERAL FUNDS

Marketing

	Dec 2017 ACTUAL	2017 ACTUAL	Dec 2018 ACTUAL	2018 FORECAST	2018 BUDGET	2019 BUDGET
<u>Media - Print</u>						
Canvet Ads	20,245	20,245	10,455	11,000	20,000	11,000
Esprit de Corps	0	0	0	0	0	0
RCMP Quarterly	0	0	0	0	0	0
Ubiquitous	0	0	0	0	0	0
Canadian Military Family	0	0	0	0	0	0
Advertising Other	0	0	0	0	0	0
<u>Media - Audio</u>						
Memorial Cup	0	0	0	0	0	0
PSA's	0	0	0	0	0	0
Audio - Other	0	0	0	0	0	0
<u>Media - Video & Photography</u>						
PSA's	0	0	0	0	0	0
Photography Services	15,236	15,236	17,013	15,000	15,000	15,000
Promotional Videos	50,818	50,818	48,477	40,000	75,000	40,000
Legion .ca Website Administration						
Video - Other 2018 Convention	0	0	6,667	6,000	6,000	0
<u>Media - Internet</u>						
Legion.ca website admin	47,216	47,216	70,763	63,000	45,000	75,000
Media Internet - Other	0	0	0	0	0	0
<u>Media - Public Relations & Events</u>						
Media Coverage & P.R. (T &F)	11,120	11,120	16,382	15,000	10,000	15,000
Media Coverage & P.R. - Other	0	0	0	0	0	0
Events/Tradeshows/Sponsorshi	19,687	19,687	35,000	35,000	35,000	35,000
<u>Programs and Campaigns</u>						
Free Membership for CF retiree:	4,056	4,056	9,410	4,000	5,000	4,000
Non Renewal Mailers	55,822	55,822	58,391	62,000	60,000	60,000
Incentive Program for Renewals /						
Recruitments (1 X 1)	0	0	0	0	0	0
Early Bird Campaign	0	0	344	0	0	0
Branch Incentive Program	0	0	0	0	0	0
Public Direct Mail Campaign						
Legion Riders Support	0	0	0	0	0	0
Marketing - Program	0	0	0	0	0	0
Design Program	1,585	1,585	3,003	5,000	7,500	3,500
Promotions and Donations	16,776	16,776	12,900	13,000	10,000	15,000
Social Media Campaign	50,000	50,000	65,437	70,000	70,000	95,000
Online Banner Campaign	64,073	64,073	75,000	75,000	75,000	75,000
Member/Branch Enewsletters	22,698	22,698	34,296	50,000	50,000	50,000
Triggered e-mail campaign	0	0	7,119	10,000	10,000	0
Invictus Games	14,658	14,658	0	0	0	0

	Dec 2017 ACTUAL	2017 ACTUAL	Dec 2018 ACTUAL	2018 FORECAST	2018 BUDGET	2019 BUDGET
Marketing Admin	0	0	0	0	0	0
Travel	0	0	5,499	5,000	5,000	5,000

Other Printed Material

Flyers and Postcards	0	0	0	0	0	0
Bookmarks	0	0	0	0	0	0
We Care Poster	0	0	0	0	0	0
Renewal Poster	0	0	0	0	0	0
Early Bird Poster	0	0	0	0	0	0
The RCL & C.F. Brochure	0	0	0	0	0	0
RCL Needs You Brochure	0	0	0	0	0	0
Posters/Brochures	0	0	0	0	0	0
RCL Welcomes You Brochure	0	0	0	0	0	0
Branch Collateral Marketing ma	31,558	31,558	61,377	60,000	40,000	40,000
Other	0	0	0	0	0	0
	425,548	425,548	537,533	539,000	538,500	538,500

THE ROYAL CANADIAN LEGION-DOMINION COMMAND
GENERAL FUNDS

Financial Services

EXPENSE	Dec		Dec			
	2017	2017	2018	2018	2018	2019
	ACTUAL	ACTUAL	ACTUAL	FORECAST	BUDGET	BUDGET
Salaries	380,163	380,163	257,468	438,208	438,208	314,000
Retirement Allowance	7,883	7,883	5,538	8,810	8,810	6,300
Other Benefits	46,459	46,459	44,062	43,760	43,760	38,700
Contract	140,664	140,664	230,501	38,311	38,311	146,000
TOTAL PERSONNEL	575,169	575,169	537,569	529,089	529,089	505,000
Office Supplies	1,347	1,347	1,058	2,000	2,000	2,000
Telephone	3,607	3,607	5,920	3,300	3,300	3,900
Postage, Express	4,586	4,586	7,473	5,000	5,000	5,000
Printing, Stationery	1,232	1,232	1,843	1,500	1,500	1,500
Staff Travel	118	118	244	200	300	150
Audit Fees	58,846	58,846	63,460	63,240	63,240	64,000
Rent (CR to Building)	29,000	29,000	29,000	29,000	29,000	29,000
Computer Network Support	3,000	3,000	7,500	7,500	7,500	7,500
Miscellaneous/Foundation Start	5,799	5,799	6,545	10,000	11,761	10,000
TOTAL EXPENSE	682,704	682,704	660,612	650,829	652,690	628,050
Less: charged to:						
Supply	79,049	79,049	46,600	57,000	57,000	57,000
Canvet	110,000	110,000	110,000	110,000	110,000	110,000
	189,049	189,049	156,600	167,000	167,000	167,000
NET EXPENSE	493,655	493,655	504,012	483,829	485,690	461,050

THE ROYAL CANADIAN LEGION-DOMINION COMMAND
GENERAL FUNDS

Veterans Services

	Dec 2017 ACTUAL	2017 ACTUAL	Dec 2018 ACTUAL	2018 FORECAST	2018 BUDGET	2019 BUDGET
REVENUE						
Poppy Fund Grant	735,000	735,000	934,600	934,600	934,600	989,045
EXPENSE						
Salaries	701,476	701,476	743,702	749,130	749,130	848,000
Retirement Allowance	14,325	14,325	13,071	14,843	14,843	16,700
Other Benefits	64,025	64,025	65,614	65,416	65,416	72,000
TOTAL PERSONNEL	779,826	779,826	822,387	829,389	829,389	936,700
Office Supplies Expense	1,198	1,198	7,926	4,000	4,000	4,000
Telephone	6,366	6,366	8,878	7,400	7,400	7,200
Postage	4,315	4,315	3,994	5,000	5,000	5,000
Staff Travel	2,759	2,759	1,543	4,000	4,000	4,000
VAC - Liaison						
Rent (Cr to Building)	45,000	45,000	45,000	45,000	45,000	45,000
Service Officers Conference	0	0	62,006	50,000	50,000	0
Advocacy and Representation	1,507	1,507	0	3,000	3,000	3,000
Administrative Support	30,000	30,000	30,000	30,000	30,000	30,000
Computer Network Support	3,000	3,000	4,500	4,500	4,500	4,500
Miscellaneous	707	707	590	1,500	1,500	1,500
TOTAL EXPENSE	874,678	874,678	986,824	983,789	983,789	1,040,900

THE ROYAL CANADIAN LEGION-DOMINION COMMAND
GENERAL FUNDS

Supply Chain Management

	Dec 2017 ACTUAL	2017 ACTUAL	Dec 2018 ACTUAL	2018 FORECAST	2018 BUDGET	2019 BUDGET
REVENUE						
Sales of Supplies	2,693,279	2,693,279	2,362,183	2,000,000	2,000,000	2,100,000
Less Cost of Goods	1,115,476	1,115,476	1,046,605	900,000	900,000	944,000
GROSS MARGIN	1,577,803	1,577,803	1,315,578	1,100,000	1,100,000	1,156,000
Legion Lager Royalty	0	0	22,890	60,000	100,000	150,000
Provincial Commands @ 5.0% of Gross Margin	78,637	78,637	66,923	58,000	60,000	65,300
EXPENSE						
Salaries	482,485	482,485	527,859	495,668	495,668	456,000
Retirement Allowance	9,939	9,939	10,627	10,202	10,202	9,000
Other Benefits	62,978	62,978	74,134	65,206	65,206	63,100
Temporary & Contract Staff	56,753	56,753	96,765	76,000	57,603	119,000
TOTAL PERSONNEL	612,155	612,155	709,385	647,076	628,679	647,100
Telephone	8,390	8,390	8,597	9,000	10,000	10,000
Postage, Express	69,314	69,314	82,026	75,000	67,000	75,000
Printing, Stationery	3,429	3,429	1,833	6,000	6,000	4,000
Staff Travel	4,384	4,384	2,543	5,000	5,000	5,000
Insurance	1,453	1,453	1,453	1,500	1,500	1,500
Rent (CR to Building)	60,000	60,000	60,000	60,000	60,000	60,000
Web Store - connectivity	32,021	32,021	13,327	10,000	4,800	10,000
Advertising/Catalogue Distributi	106,900	106,900	62,449	60,000	60,000	80,000
Wrapping Material	35,037	35,037	28,962	35,000	31,000	38,000
Finance/Administration Support	68,033	68,033	46,600	57,000	57,000	57,000
Office Supplies	1,611	1,611	1,956	2,000	2,000	2,000
Bad Debts	0	0	0	0	400	0
Computer Network Support	6,000	6,000	7,500	7,500	7,500	7,500
Miscellaneous	1,921	1,921	1,519	1,600	1,600	1,600
EXPENSE TOTAL	1,089,285	1,089,285	1,095,073	1,034,676	1,002,479	1,064,000
Less: Poppy Fund Chargeback	-269,100	-269,100	-274,482	-274,482	-274,482	-278,600
NET EXPENSE	820,185	820,185	820,591	760,194	727,997	785,400
GAIN OR (LOSS)	757,618	757,618	517,877	399,806	472,003	520,600

THE ROYAL CANADIAN LEGION-DOMINION COMMAND
 GENERAL FUNDS

Other Program Expenses

	Dec 2017 ACTUAL	2017 ACTUAL	Dec 2018 ACTUAL	2018 FORECAST	2018 BUDGET	2019 BUDGET
RCEL						
Conference	5,000	5,000	5,000	5,000	5,000	5,000
SCOWP	1,116	1,116	1,582	2,000	2,000	2,000
RCEL TOTAL	6,116	6,116	6,582	7,000	7,000	7,000
OTHER						
Request for Support	8,000	8,000	7,000	15,000	15,000	15,000
Annual General Meeting	3,468	3,468	0	0	0	4,000
Legion Representation on Local	0	0	0	500	500	500
Historica (EWC)	23	23	23	0	0	0
Legal & Other	133,581	133,581	247,634	70,000	70,000	55,000
Charitable Foundation Start Up	21,587	21,587	0	10,000	10,000	0
MBP Ads	22,203	22,203	22,863	20,000	20,000	20,000
Translation	21,896	21,896	30,906	40,000	40,000	27,500
TOTAL EXPENSE	216,874	216,874	315,008	162,500	162,500	129,000

THE ROYAL CANADIAN LEGION-DOMINION COMMAND
GENERAL FUNDS

Legion House

	Dec 2017 ACTUAL	2017 ACTUAL	Dec 2018 ACTUAL	2018 FORECAST	2018 BUDGET	2019 BUDGET
REVENUE						
Rent - Tenants	82,920	82,920	82,920	82,920	82,920	82,920
Rent - charged to Departments						
- Administration	108,000	108,000	108,000	108,000	108,000	108,000
- Marketing & Membership	54,000	54,000	54,000	54,000	54,000	54,000
- Membership						
- Marketing	10,000	10,000	10,000	10,000	10,000	10,000
- Service Bureau	45,000	45,000	45,000	45,000	45,000	45,000
- Supply Dept	60,000	60,000	60,000	60,000	60,000	60,000
- Finance	29,000	29,000	29,000	29,000	29,000	29,000
- IT Section	10,000	10,000	10,000	10,000	10,000	10,000
TOTAL REVENUE	398,920	398,920	398,920	398,920	398,920	398,920
EXPENSE						
Salaries	27,001	27,001	29,740	27,766	27,766	28,100
Retirement Allowance	557	557	654	609	609	600
Other Benefits	4,589	4,589	4,850	4,085	4,085	4,300
TOTAL PERSONNEL	32,147	32,147	35,244	32,460	32,460	33,000
Elevator Maintenance	4,116	4,116	6,314	7,000	7,000	7,000
A/C, Electrical, Plumbing	18,561	18,561	42,519	32,000	32,000	32,000
Interior & Exterior	77,612	77,612	95,931	95,000	0	82,000
Major Repairs	3,307	3,307	101,231	5,000	80,000	0
Cleaning Contract & Supplies	45,885	45,885	47,907	48,000	52,000	52,000
Fuel	10,436	10,436	12,199	13,000	13,000	13,000
Light & Power	59,956	59,956	57,553	60,000	62,000	62,000
Water and Sewage	1,937	1,937	3,627	2,400	2,000	2,400
Taxes	55,184	55,184	56,471	56,000	56,500	56,500
Insurance	4,122	4,122	4,124	5,000	5,000	4,500
Reserve Fund	30,000	30,000	0	0	0	0
TOTAL EXPENSES	343,263	343,263	463,120	355,860	341,960	344,400
GAIN OR LOSS	55,657	55,657	-64,200	43,060	56,960	54,520

THE ROYAL CANADIAN LEGION-DOMINION COMMAND
GENERAL FUNDS

Committees & Elected Officers Expense

	Dec 2017 ACTUAL	2017 ACTUAL	Dec 2018 ACTUAL	2018 FORECAST	2018 BUDGET	2019 BUDGET
COMMITTEES						
Veterans, Service and Seniors	17,083	17,083	17,144	32,500	32,500	32,500
Poppy & Remembrance	24,008	24,008	30,021	27,450	28,950	27,450
Membership	4,815	4,815	13,947	16,250	16,250	15,250
Public Relations	90,233	90,233	115,664	131,459	142,595	144,450
RCEL	355	355	700	1,195	675	675
Sports	328,482	328,482	320,035	347,100	357,700	336,400
Ritual & Awards	4,388	4,388	2,220	2,000	2,000	2,000
Constitution & Laws	10,858	10,858	3,855	1,200	2,550	1,850
Defence & Security	22,877	22,877	25,086	28,525	32,800	28,600
Veterans Consultation (FOF) Going Forward	1,102	1,102	1,253	3,900	4,000	3,900
Leadership Development	19	19	0	40	200	100
COMMITTEE TOTAL	505,598	505,598	542,927	604,619	674,220	598,775
Elected Officers	72,550	72,550	52,003	104,500	104,500	130,250
DEC/Senior Elected Officers	88,707	88,707	65,126	71,400	71,400	71,400
Dominion Convention	206,826	206,826	95,821	148,006	148,016	207,450
SUB-TOTAL	368,083	368,083	212,950	323,906	323,916	409,100
TOTAL EXPENSE	873,681	873,681	755,877	928,525	998,136	1,007,875

THE ROYAL CANADIAN LEGIOIN-DOMINION COMMAND

Veterans, Service & Seniors

	Dec 2017	2017	Dec 2018	2018	2018	2019
<u>COMMITTEE</u>	ACTUAL	ACTUAL	ACTUAL	FORECAST	BUDGET	BUDGET
Travel	681	681	2,195	7,500	7,500	7,500
Per Diem	0	0	3,053	6,000	6,000	6,000
CIMVHR Forum	12,357	12,357	10,030	10,000	10,000	10,000
Printing, Stationery	401	401	62	500	500	500
Telephone & Fax	294	294	319	600	600	600
Postage	2	2	316	400	400	400
Business Transformation Initiati	1,163	1,163	0	1,500	1,500	1,500
Homeless Veterans Summit	2,159	2,159	0	5,000	5,000	5,000
Miscellaneous	25	25	1,170	1,000	1,000	1,000
TOTAL	17,082	17,082	17,145	32,500	32,500	32,500

THE ROYAL CANADIAN LEGION-DOMINION COMMAND

Poppy & Remembrance Committee

	Dec 2017 ACTUAL	2017 ACTUAL	Dec 2018 ACTUAL	2018 FORECAST	2018 BUDGET	2019 BUDGET
<u>COMMITTEE</u>						
Travel	1,373	1,373	4,450	7,000	7,000	7,000
Per Diem	1,371	1,371	2,649	2,000	2,000	2,000
Postage & Office	1,163	1,163	5,530	1,000	1,000	1,000
Telephone and Fax	52	52	81	1,000	1,000	1,000
Teachers Guide	0	0	0	0	0	0
Miscellaneous	459	459	903	500	500	500
TOTAL	4,418	4,418	13,613	11,500	11,500	11,500
<u>EUROPE ZONE</u>						
Grant						
Europe - Wreaths	123	123	0	0	1,500	0
	123	123	0	0	1,500	0
<u>NATIONAL CEREMONIES</u>						
Travel	1,739	1,739	1,579	4,500	4,500	4,500
Per Diem	1,340	1,340	387	4,500	4,500	4,500
Printing, Stationery	3,534	3,534	4,792	500	500	500
Telephone, Postage	549	549	1,527	500	500	500
Colour Party Activities						
- Summer & Fall	1,727	1,727	214	250	250	250
Meeting, Planning	129	129	139	200	200	200
St. John's Ambulance	500	500	0	500	500	500
Ceremonies Operations	10,975	10,975	7,770	5,000	5,000	5,000
TOTAL	20,493	20,493	16,408	15,950	15,950	15,950
<u>PILGRIMAGE</u>						
Poppy Grant	-36,627	-36,627	0	0	-33,750	0
Expenses	35,600	35,600	0	0	33,750	0
TOTAL	-1,027	-1,027	0	0	0	0
TOTAL	24,007	24,007	30,021	27,450	28,950	27,450
Europe - Wreaths	0	0	104	1,000	1,000	1,500
Remembrance Reception	0	0	9,065	6,000	6,000	6,000
Silver Cross Mother	3,743	3,743	4,737	5,000	5,000	5,000
Cadet of the Year	8,002	8,002	7,139	10,000	10,000	10,000
National Literary/Poppy Contest						
Travel	5,380	5,380	2,891	7,000	7,000	7,000
Per Diem	4,868	4,868	2,776	5,000	5,000	5,000
Bursaries/Gifts	11,971	11,971	13,021	12,000	12,000	12,000
Total - Poppy Fund	33,964	33,964	39,733	46,000	46,000	46,500
Total - General Fund	24,007	24,007	30,021	27,450	28,950	27,450
Total - National Remembrance Ceremony	57,974	57,974	69,754	73,450	74,950	73,950

THE ROYAL CANADIAN LEGION-DOMINION COMMAND

MEMBERSHIP COMMITTEE

	Dec 2017	2017	Dec 2018	2018	2018	2019
<u>COMMITTEE</u>	ACTUAL	ACTUAL	ACTUAL	FORECAST	BUDGET	BUDGET
Travel	0	0	2,214	2,500	2,500	2,500
Per Diem	0	0	1,996	3,500	3,500	3,500
Printing and Office	725	725	0	750	750	750
Postage	0	0	0	0	0	0
Focus Group Study	0	0	0	1,500	2,500	0
Telephone & Fax	0	0	0	0	0	0
Miscellaneous	784	784	1,631	1,000	0	1,000
	1,509	1,509	5,841	9,250	9,250	7,750
<u>PRINTING & STATIONERY</u>						
Membership Forms	902	902	5,961	4,500	5,000	5,000
Early Bird Stickers	2,404	2,404	2,145	2,500	2,000	2,500
	3,306	3,306	8,106	7,000	7,000	7,500
TOTAL	4,815	4,815	13,947	16,250	16,250	15,250

THE ROYAL CANADIAN LEGION-DOMINION COMMAND

PUBLIC RELATIONS

	Dec 2017	2017	Dec 2018	2018	2018	2019
	ACTUAL	ACTUAL	ACTUAL	FORECAST	BUDGET	BUDGET
<u>COMMITTEE</u>						
Travel	0	0	0	2,000	4,500	2,000
Per Diem	90	90	339	1,000	4,000	1,000
Printing, Stationery	33	33	0	100	100	100
Telephone & Fax	201	201	357	750	750	750
Postage	0	0	28	9	0	0
<u>Publications</u>						
- Write off old stock	0	0	0	0	0	0
- Distribution of new stock	0	0	0	0	0	0
Miscellaneous	138	138	55	100	100	100
SUB-TOTAL	462	462	779	3,959	9,450	3,950

PR SECTION

External

Media Monitoring	7,458	7,458	30,407	25,000	25,000	38,000
Media Distribution	22,107	22,107	5,714	3,000	5,645	3,000
Specialist Consulting	41,213	41,213	10,261	20,000	20,000	20,000
National Memorial Ride	15,004	15,004	12,724	15,000	15,000	15,000
National Memorial Ride Donatio	0	0	-2,080	0	0	0
Partnership/Event PR Support	0	0	22,617	20,000	20,000	20,000
<u>Training/Liaison</u>						
- Per Diem	3,685	3,685	5,444	15,000	15,000	15,000
- Travel	305	305	9,875	12,500	12,500	12,500
- PR Training	0	0	19,923	17,000	20,000	17,000
SUB-TOTAL	89,772	89,772	114,885	127,500	133,145	140,500
GRAND TOTAL	90,233	90,233	115,664	131,459	142,595	144,450

THE ROYAL CANADIAN LEGION-DOMINION COMMAND

	RCEL COMMITTEE					
	Dec 2017	2017	Dec 2018	2018	2018	2019
	ACTUAL	ACTUAL	ACTUAL	FORECAST	BUDGET	BUDGET

Meetings:

Committee

-Per Diem	355	355	700	1,195	675	675
Total	355	355	700	1,195	675	675

THE ROYAL CANADIAN LEGION-DOMINION COMMAND

SPORTS COMMITTEE

	Dec 2017 ACTUAL	2017 ACTUAL	Dec 2018 ACTUAL	2018 FORECAST	2018 BUDGET	2019 BUDGET
COMMITTEE						
Travel	4,488	4,488	3,380	4,500	3,750	4,800
Per Diem	5,701	5,701	2,246	5,500	3,750	5,500
T & F - LAC						
- Spring Site Visit	0	0	8,007	8,000	6,000	8,500
- Fall Site Visit	0	0	5,836	5,000	0	0
Printing, Stationery	3,215	3,215	534	1,000	1,000	1,000
Telephone & Fax	102	102	166	200	200	200
Postage	688	688	437	300	300	300
Miscellaneous	0	0	3,878	1,300	1,000	1,500
TOTAL COMMITTEE	14,194	14,194	24,484	25,800	16,000	21,800

DARTS

Travel						
- Participants	19,288	19,288	20,005	20,500	22,000	24,000
- Committee	1,341	1,341	850	900	1,500	1,600
Awards & Prizes-participants	1,694	1,694	1,299	1,300	1,300	1,400
Advance to Host Branch	800	800	800	800	800	800
Ground Transportation	1,500	1,500	1,500	1,500	1,500	1,500
TOTAL DARTS	24,623	24,623	24,454	25,000	27,100	29,300

CRIBBAGE

Travel						
- Participants	16,916	16,916	24,331	24,000	26,000	24,000
- Committee	1,635	1,635	1,829	1,800	1,500	1,600
Awards & Prizes	1,074	1,074	1,243	1,200	1,300	1,400
Advance to Host Branch	800	800	800	800	800	800
Ground Transportation	1,500	1,500	1,500	1,500	1,500	1,500
TOTAL CRIBBAGE	21,925	21,925	29,703	29,300	31,100	29,300

EIGHT BALL

Travel						
- Participants	16,401	16,401	15,586	16,000	22,000	22,000
- Committee	2,006	2,006	1,033	1,100	1,500	1,600
Awards & Prizes	1,065	1,065	1,270	1,200	1,300	1,400
Advance to Host Branch	800	800	800	800	800	800
Ground Transportation	1,614	1,614	1,500	1,500	1,500	1,500
TOTAL EIGHT BALL	21,886	21,886	20,189	20,600	27,100	27,300
TOTAL MEMBERS SPORTS	68,434	68,434	74,346	74,900	85,300	85,900
TOTAL T & F	245,854	245,854	221,205	246,400	256,400	228,700
TOTAL SPORTS & COMMIT	328,482	328,482	320,035	347,100	357,700	336,400

THE ROYAL CANADIAN LEGION-DOMINION COMMAND

NATIONAL TRACK & FIELD

	Dec 2017	2017	Dec 2018	2018	2018	2019
	ACTUAL	ACTUAL	ACTUAL	FORECAST	BUDGET	BUDGET
Transportation	180,440	180,440	163,673	170,000	186,000	210,000
Accommodations, Meals	169,433	169,433	179,466	181,000	175,000	175,000
Committee - Travel	13,545	13,545	5,857	13,000	9,700	13,000
Committee - Per Diem	17,440	17,440	18,987	8,000	7,000	8,000
Local Committee	0	0	1,061	1,000	1,000	1,000
Kits / Supplies / Medals	14,094	14,094	10,466	8,000	5,000	8,000
Buses	11,112	11,112	12,285	12,000	12,000	20,000
Honoraria	3,000	3,000	3,000	3,000	3,000	3,000
Reception	1,500	1,500	1,806	1,500	1,500	1,500
Medical	0	0	0	200	200	200
Athletic Facilities	0	0	550	500	1,500	1,500
Equipment / Mtg Rooms	374	374	494	700	1,500	1,500
Clinicians	595	595	1,114	1,000	1,000	1,000
Officials	869	869	2,239	1,000	2,000	2,000
Commemorative Expenses	2,829	2,829	10,525	12,000	8,000	0
Freight & Express	1,467	1,467	960	2,500	2,000	2,000
Miscellaneous	847	847	4,117	2,000	1,000	1,000
TOTAL EXPENSE	417,545	417,545	416,600	417,400	417,400	448,700
Less Prov Cmd Portion	-110,384	-110,384	-114,869	-100,000	-100,000	-100,000
SUB TOTAL	307,162	307,162	301,732	317,400	317,400	348,700
RECOVERIES						
Registration - Non Legion Atf	-25,308	-25,308	-27,700	-25,000	-25,000	-25,000
Sponsorships	-16,000	-16,000	-52,000	-46,000	-36,000	-20,000
Grant-VAC	-20,000	-20,000	0	0	0	0
Centennial Fund	0	0	0	0	0	-75,000
Other	0	0	-827	0	0	0
Total Recoveries	-61,308	-61,308	-80,527	-71,000	-61,000	-120,000
NET EXPENSE	245,854	245,854	221,205	246,400	256,400	228,700

THE ROYAL CANADAIN LEGION-DOMINION COMMAND

	RITUAL & AWARDS					
	Dec 2017 ACTUAL	2017 ACTUAL	Dec 2018 ACTUAL	2018 FORECAST	2018 BUDGET	2019 BUDGET
Travel	670	670	672	700	700	700
Per Diem	624	624	652	1,000	1,000	1,000
Printing, Stationery	2,281	2,281	549	100	100	100
Telephone & Fax	174	174	132	100	100	100
Postage	640	640	3	100	100	100
<u>Publications</u>						
- Distribution of new stock	0	0	212	0	0	0
TOTAL	4,389	4,389	2,220	2,000	2,000	2,000

THE ROYAL CANADIAN LEGION-DOMINION COMMAND

CONSTITUTIONS & LAWS COMMITTEE

	Dec 2017	2017	Dec 2018	2018	2018	2019
	ACTUAL	ACTUAL	ACTUAL	FORECAST	BUDGET	BUDGET
Travel	5,146	5,146	1,464	300	1,300	500
Per Diem	3,182	3,182	812	100	500	500
Printing, Stationery	1,111	1,111	11	50	250	250
Telephone & Fax	165	165	251	100	100	200
Postage	1,083	1,083	258	50	100	100
Miscellaneous	170	170	57	50	0	0
<u>Publications</u>						
- Revision to On-Line Manuals	0	0	963	550	300	300
TOTAL	10,857	10,857	3,816	1,200	2,550	1,850

THE ROYAL CANADIAN LEGION-DOMINION COMMAND

	DEFENCE & SECURITY COMMITTEE					
	Dec 2017		Dec 2018		2018	2019
	ACTUAL	ACTUAL	ACTUAL	FORECAST	BUDGET	BUDGET
Travel	693	693	578	2,000	4,500	2,000
Per Diem	873	873	0	950	4,500	1,000
Printing, Postage,	242	242	101	225	100	250
Telephone & Fax	36	36	19	250	250	250
Miscellaneous	0	0	0	250	250	250
Annual Vimy Award & AGM	5,122	5,122	6,740	6,000	6,000	6,000
Conference of Defence Association Fee & CIC Fee	2,693	2,693	2,000	3,850	2,200	3,850
Comradeship Awards	3,220	3,220	5,063	3,000	3,000	3,000
<u>CF Sponsorships</u>						
- Operation Canada Day	0	0	0	0	0	0
- Nijmegen	10,000	10,000	10,584	12,000	12,000	12,000
TOTAL EXPENSE	22,879	22,879	25,085	28,525	32,800	28,600

THE ROYAL CANADIAN LEGION-DOMINION COMMAND

VETERANS CONSULTION

	Dec 2017	2017	Dec 2018	2018	2018	2019
	ACTUAL	ACTUAL	ACTUAL	FORECAST	BUDGET	BUDGET
Travel	505	505	785	2,500	2,600	2,500
Per Diem	566	566	455	1,300	1,300	1,300
Printing & Office	0	0	13	50	50	50
Telephone	0	0	0	0	0	0
Miscellaneous	32	32	0	50	50	50
TOTAL	1,103	1,103	1,253	3,900	4,000	3,900

THE ROYAL CANADIAN LEGION-DOMINION COMMAND

(FOF) Going Forward Committee

	Dec 2017	2017	Dec 2018	2018	2018	2019
	ACTUAL	ACTUAL	ACTUAL	FORECAST	BUDGET	BUDGET
Travel	788	788	6,501	6,500	2,600	3,000
Per Diem	590	590	5,997	6,000	1,300	2,500
Printing	0	0	500	500	100	100
Postage	0	0	0	0	0	0
Telephone & Fax	0	0	0	0	0	0
Consultant/Strategic Project	0	0	0	0	50,000	0
TOTAL	1,378	1,378	12,998	13,000	54,000	5,600

THE ROYAL CANADIAN LEGION-DOMINION COMMAND

LEADERSHIP & DEVELOPMENT

	Dec 2017	2017	Dec 2018	2018	2018	2019
	ACTUAL	ACTUAL	ACTUAL	FORECAST	BUDGET	BUDGET
Travel	0	0	0	0	0	0
Per Diem	0	0	0	0	0	0
Printing & Office	0	0	0	0	0	0
Postage	0	0	0	0	0	0
Telephone & Fax	19	19	0	40	200	100
Miscellaneous	0	0	0	0	0	0
TOTAL	19	19	0	40	200	100

THE ROYAL CANADIAN LEGION-DOMINION COMMAND

ELECTED OFFICERS & DOMINION PRESIDENT

	Dec 2017	2017	Dec 2018	2018	2018	2019
	ACTUAL	ACTUAL	ACTUAL	FORECAST	BUDGET	BUDGET
ELECTED OFFICERS:						
Travel	1,103	1,103	2,540	10,000	10,000	10,000
Per Diem	1,802	1,802	2,298	4,000	4,000	4,000
Telephone & Fax	0	0	8	0	0	0
Miscellaneous	1,270	1,270	716	0	0	500
SUB-TOTAL	4,175	4,175	5,562	14,000	14,000	14,500

DOMINION PRESIDENT:

Travel	13,151	13,151	18,299	48,500	48,500	48,500
Per Diem	20,448	20,448	9,416	24,500	24,500	24,500
Hospitality	3,693	3,693	8,599	5,000	5,000	5,000
Telephone & Postage	1,805	1,805	2,931	2,500	2,500	4,250
Miscellaneous	6,160	6,160	7,196	10,000	10,000	7,500
SUB-TOTAL	45,257	45,257	46,441	90,500	90,500	89,750

PROVINCIAL CONVENTIONS:

Travel	11,238	11,238	0	0	0	13,000
Per Diem	11,879	11,879	0	0	0	13,000
SUB-TOTAL	23,117	23,117	0	0	0	26,000
TOTAL	72,549	72,549	52,003	104,500	104,500	130,250

THE ROYAL CANADIAN LEGION-DOMINION COMMAND

DOMINION EXECUTIVE COUNCIL

	Dec 2017 ACTUAL	2017 ACTUAL	Dec 2018 ACTUAL	2018 FORECAST	2018 BUDGET	2019 BUDGET
D.E.C. MEETINGS:						
Travel	32,978	32,978	30,199	32,000	32,000	32,000
Per Diem	41,397	41,397	23,774	32,000	32,000	32,000
Printing	0	0	397	100	100	100
Telephone, Fax & Postage	247	247	23	100	100	100
Miscellaneous	2,780	2,780	2,941	2,000	2,000	2,000
SUB-TOTAL D.E.C. MEETING:	77,402	77,402	57,334	66,200	66,200	66,200
SENIOR ELECTED OFFICERS MEETINGS:						
Travel	7,802	7,802	7,329	5,500	5,500	5,500
Per Diem	9,503	9,503	6,442	5,500	5,500	5,500
Telephone, Fax & Postage	0	0	20	100	100	100
Printing	0	0	0	100	100	100
Miscellaneous	0	0	0	0	0	0
	17,305	17,305	13,791	11,200	11,200	11,200
LESS:						
Canvet Board and Shareholders	-6,000	-6,000	-6,000	-6,000	-6,000	-6,000
TOTAL	88,707	88,707	65,126	71,400	71,400	71,400

THE ROYAL CANADIAN LEGION-DOMINION COMMAND

Dominion Convention

	Dec 2017 ACTUAL	2017 ACTUAL	Dec 2018 ACTUAL	2018 FORECAST	2018 BUDGET	2019 BUDGET
DEC						
Travel	0	0	16,723	20,000	20,000	0
Per Diem	0	0	42,608	54,538	54,538	0
Staff						
Travel	0	0	19,044	20,000	20,000	0
Per Diem	1,928	1,928	19,676	57,451	57,451	0
Past President						
Travel	0	0	3,963	4,000	4,000	0
Per Diem	0	0	8,953	11,975	11,975	0
DC Zone Commanders						
Travel	0	0	1,216	5,000	5,000	0
Per Diem	0	0	412	6,060	6,060	0
Other						
Travel	0	0	3,883	6,000	6,000	0
Per Diem	0	0	3,508	12,848	12,848	0
Entertainment	0	0	216	2,000	2,000	0
Credentials	0	0	2,080	0	0	0
Printing & Design						
Convention Reports	-1,300	-1,300	21,731	22,000	22,000	0
Other	0	0	2,414	4,000	4,000	0
Translation & Interpretation	0	0	0	0	0	0
Postage	1	1	18,816	18,000	18,000	0
Freight	0	0	11,839	4,000	4,000	0
Social Activities						
President Reception	0	0	13,895	5,000	5,000	0
Other	0	0	0	0	0	0
Convention Centre	0	0	47,595	60,000	60,000	0
Convention Operation	0	0	167,228	90,000	90,000	0
Transportation	0	0	0	10,000	10,000	0
Ceremonies	0	0	581	500	500	0
Local Arrangements Committee	0	0	4,630	5,000	5,000	0
Supply	223	223	18	0	0	0
	852	852	411,029	418,372	418,372	0
Revenue	0	0	69,319	80,566	80,566	0
SUB-TOTAL	852	852	341,712	337,806	337,816	0
Provision	200,000	200,000	-200,000	-200,000	-200,000	200,000
SUB TOTAL	200,852	200,852	141,712	137,806	137,816	200,000
Recoveries	0	0	-50,622	0	0	0
Total	200,852	200,852	91,090	137,806	137,816	200,000
COMMITTEE (FROM 15A)	5,974	5,974	4,731	10,200	10,200	7,450
TOTAL CONVENTION AND	206,826	206,826	95,821	148,006	148,016	207,450

THE ROYAL CANADIAN REGION-DOMINION COMMAND

Convention Committee

	Dec 2017	2017	Dec 2018	2018	2018	2019
	ACTUAL	ACTUAL	ACTUAL	FORECAST	BUDGET	BUDGET
Travel	4,025	4,025	2,121	5,500	5,500	4,500
Per Diem	1,926	1,926	676	4,000	4,000	2,500
Printing, Stationery	14	14	1,517	100	100	50
Telephone & Fax	0	0	0	0	0	0
Postage	9	9	324	100	100	100
Miscellaneous	0	0	92	500	500	300
TOTAL	5,974	5,974	4,730	10,200	10,200	7,450



Royal Commonwealth Ex-Services League

**Chris Warren
Secretary General**

Briefing to The Royal Canadian Legion



Royal Commonwealth Ex-Services League

Setting the context

DFID/UKAid Programme

Royal Commonwealth Ex-Services League



**The League was founded in 1921 by
Field Marshal Earl Haig and General Smuts in
Cape Town South Africa**

Royal Commonwealth Ex-Services League



The Founding Nations were:-

- Australia
- Canada
- New Zealand
- South Africa
- United Kingdom



Royal Commonwealth Ex-Services League



Object of the League:-

“By Charitable means to seek to ensure that no eligible Commonwealth ex-service man or woman shall be without help if in need.”

Royal Commonwealth Ex-Services League



WORLD WARS

- 7.5 million Commonwealth soldiers fought in both World Wars
- There were 800,000 casualties

Royal Commonwealth Ex-Services League



RCEL TODAY

- 1981 co-located with The Royal British Legion
- 57 Member Organisations / 48 different countries
- 12,000 eligible, pre-independence veterans and widows
- Increasing number die each year

Royal Commonwealth Ex-Services League



Royal Commonwealth Ex-Services League - Global Support for Veterans

Address
Haig House
199 Borough High Street
London SE1 1AA
United Kingdom

Telephone
+44 (0)20 3207 2413

Email
mgordon-roe@commonwealthveterans.org.uk

Website
www.commonwealthveterans.org.uk

Registered Charity No.
231322

1. AUSTRALIA	9. CAYMAN ISLANDS	17. GUYANA	25. MALTA	33. ST LUCIA	41. SRI LANKA
2. BAHAMAS	10. CYPRUS	18. HONG KONG	26. MAURITIUS	34. ST VINCENT & THE GRENADINES	42. SWAZILAND
3. BANGLADESH	11. DOMINICA	19. INDIA	27. MONTSERRAT	35. SCOTLAND	43. TANZANIA
4. BARBADOS	12. ENGLAND, WALES & NORTHERN IRELAND	20. JAMAICA	28. NAMIBIA	36. SEYCHELLES	44. TRINIDAD & TOBAGO
5. BELIZE	13. FIJI	21. KENYA	29. NEW ZEALAND	37. SIERRA LEONE	45. TURKS & CAICOS
6. BURMA	14. GAMBIA	22. LESOTHO	30. NIGERIA	38. SINGAPORE	46. UGANDA
7. CAMEROON	15. GHANA	23. MALAWI	31. PAKISTAN	39. SOMALIA	47. ZAMBIA
8. CANADA	16. GRENADA	24. MALAYSIA	32. ST KITTS & NEVIS	40. SOUTH AFRICA	48. ZIMBABWE

RCEL ORGANISATION CHART

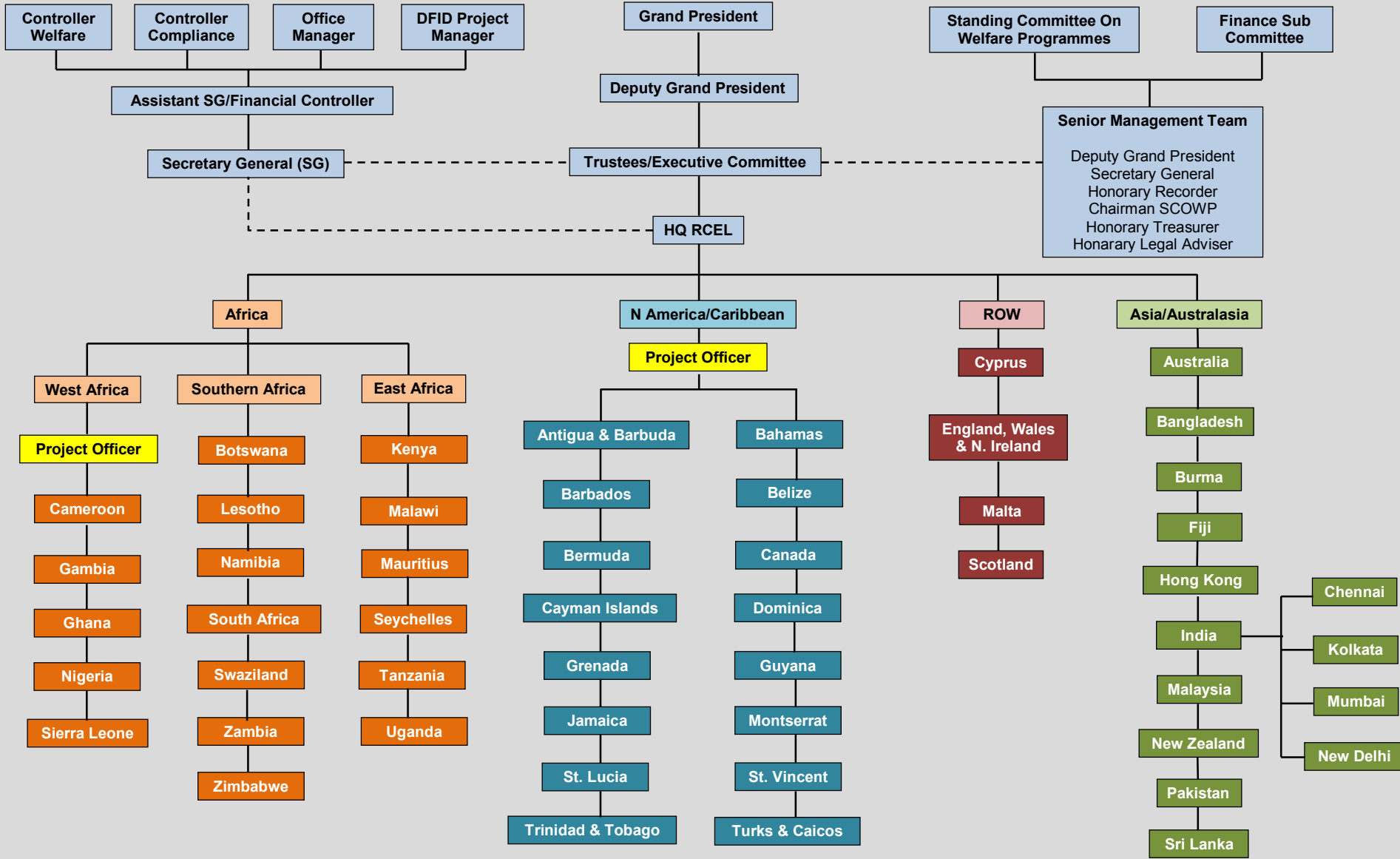

Royal Commonwealth Ex-Services League



RESIDENT OVERSEAS PROJECT OFFICERS

Derrick Cobbinah – West Africa
Johanna Lewin – The Caribbean

Royal Commonwealth Ex-Services League



GOVERNANCE

- Conference (every 5 years)
- Articles of Association - CIO
- Commonwealth Council (some DAs)
- Executive Committee
- Finance Committee
- Welfare Committee

TOURS



- 9 -12 countries visited each year
- Every 3 years
- 3 days with each country (audit and visit veterans receiving help)
- Rules
- Report (honest and restricted distribution)
- Media focus on overseas aid – independent Audit Report

Royal Commonwealth Ex-Services League



TRBL SUPPORT

- Office Accommodation / Services – £51,000
- £42,000 free poppies to Member Organisations
- Annual donation - £240,000
- TRBL Chairman a Trustee
- TRBL Director Welfare a member of our Welfare Committee
- All our beneficiaries are eligible for TRBL welfare grants

Royal Commonwealth Ex-Services League



ABF THE SOLDIERS CHARITY SUPPORT

- Annual grant of £220,000
- Agency grants:
 - 2018 - £105,900
 - 2017 - £66,080
 - 2016 - £69,125
 - 2015 - £71,584

Royal Commonwealth Ex-Services League



TYPE OF WELFARE GRANTS 2018

- RCEL - £1,904,566
- Restricted - £898,506
- Royal Canadian Legion - £142,305

Royal Commonwealth Ex-Services League



RCEL WELFARE GRANTS

- Disaster-Emergency Relief
- Projects
- Individual Welfare: £300 - £700 per year
- Zimbabwe Care Home - £3,000
- 2018 - £1,904,566

Royal Commonwealth Ex-Services League



DISASTER - EMERGENCY RELIEF

Distribution of Food Parcels



Flooding in Chin State, Burma



Uganda – Hailstorm and Flooding



Sierra Leone – Flooding and Mudslides



Royal Commonwealth Ex-Services League



PROJECTS

Kenya – Maize Mill Project



SLESA Mini Bus



Royal Commonwealth Ex-Services League



INDIVIDUAL WELFARE GRANTS

Two WWII
Veterans in the
Seychelles proudly
displaying their
medals



Royal Commonwealth Ex-Services League



AGENCY WORK

- On behalf of over 45 military charities
- Member Organisation carry out the in-country case work, collect money from related charities, transfer funds and have grants delivered
- 796 cases in 2018

Algernon
Taffs in
Zimbabwe



Hurricane destruction in Dominica



Steven John-
Baptiste's
house in
Dominica

Commonwealth Veterans Review Committee



- Chair Sir Malcolm Rifkind
- CVRC consists of the major Service Charities
- Raise awareness
- Government support

Commonwealth Veterans Review Committee



- To provide 2 meals a day – 2400 calories
- To all Member Organisations
- April 2019 – March 2024
- To be provided in annual payments

Department for International Development (DFID)



- To provide 2 meals a day – 2400 calories
- To 30 Member Organisations
- April 2019 – March 2024
- To be provided in 6 monthly payments
- A terabyte of governance

Department for International Development (DFID)



- West African countries included on the DFID list:
 - Ghana (105), Gambia (102), Sierra Leone (69), Cameroon (63)
- West African countries not included on the DFID list:
 - Nigeria (410)

Department for International Development (DFID)



- Included on the DFID list:
 - Antigua (7), Belize (9), Dominica (6), Grenada (7), Guyana (33), Jamaica (?), Montserrat, St Lucia (20), St Vincent (4)
- Not included on the DFID list:
 - Bahamas, Barbados, Bermuda, Cayman Islands, St Kitts, Trinidad and Tobago, Turks and Caicos

Department for International Development (DFID)



- Numbers on the list are 42 veterans and 54 widows. None in Montserrat
- Numbers not included on the DFID list are 14 veterans and 32 widows in 3 countries:
 - Bahamas (34)
 - St Kitts (1)
 - Trinidad (6) and Tobago (5)

Department for International Development (DFID) Options



- The RCL distributes additional DFID/UKAid funding of £100,000 twice a year
- The RCEL distributes DFID/UKAid funding
- The RCL supports non DFID/UKAid countries?

Royal Commonwealth Ex-Services League



SUMMARY

- Only UK based military charity with a global reach
- DFID/UKAid 5 year programme
- The Royal Canadian Legion support to the Caribbean
- The way ahead?

**REPORT OF THE DOMINION COMMAND
VETERANS, SERVICES AND SENIORS COMMITTEE
TO THE DOMINION EXECUTIVE COUNCIL
28-29 APRIL 2018**

65-1

T. Irvine	-	Chair
B. Julian	-	Vice- Chair
R. Anderson	-	Member
J. Mahon	-	Member
D. Gordon	-	Homeless Veterans
G. O'Dair	-	Seniors Advisor
C. Richardson	-	BSO Legion OSI Special Section
L. Murray	-	Ex-Officio Member
R. McInnis	-	Facilitator
D. McCarthy	-	A/Facilitator

GENERAL

The VSS Committee last met on 13 February 2019 via teleconference. Since the last report, Budget 2019 was released, Pension for Life was implemented on 1 April and a new Minister of Veterans Affairs was appointed.

LEGION ADVOCACY

Advocacy efforts have focused on ensuring that all Veterans and their families are treated with fairness, dignity and respect such that they are afforded the same benefits and services irrespective of when and where they served.

The Dominion President / VSS Chair and Committee continued to address key issues affecting Veterans and their families:

- a. The President hosted an informal meeting with the new Veterans Ombudsman, Craig Dalton on 14 March 2019 to review advocacy issues.
- b. The President appeared before the Senate on 27 February 2019 with Comrades Steven Clark and Nujma Bond to speak on the effect the revolving door of Ministers in Veterans Affairs was having on the veteran community. Soon after the brief, the PM appointed Lawrence MacAulay as the new Minister.
- c. Comrades Ray McInnis and Dave Gordon appeared before ACVA on 22 November 2018 to discuss homeless veterans.
- d. Comrade Ray McInnis appeared before the Senate on 5 December 2018 to speak on medical marijuana.

- e. We will be requesting the new Minister to deliver on the national homeless veterans strategy and departmental or government standards for psychiatric service dogs.

CIMVHR

The next CIMVHR Forum will be held in Gatineau, Quebec from 21-23 October 2019.

At the VSS Committee meeting on 24 November 2018, the Committee approved to recommend to the Poppy and Remembrance Committee and DEC to continue the RCL Masters Scholarship for another three-year cycle, starting in 2020-2021 ending in 2022-2023, for a total of \$90,000.00 from the Dominion Command Poppy Trust Fund.

The P&R Committee reviewed this requirement and was satisfied that the request met the requirements for the use of Poppy Funds.

RECOMMENDATION: It was recommended that \$90,000 be allocated from Poppy Funds to support the RCL Masters Scholarship for another three-year cycle, starting in 2020-2021 ending in 2022-2023.

PROJECT HEALING WATERS

The VSS Committee reviewed and concurred with a proposal from Project Healing Waters for \$25,000.00 from the Dominion Command Poppy Trust Fund. This organization was not successful with their request to VAC under the Veterans and Family Well-being Fund. This social rehabilitation program provides life-long skills and equipment to Veterans at a low cost.

They will hold five events in 2019 for 91 Veterans, approximately \$275.00 per Veteran attending these events. Note that they are also submitting proposals to Provincial Commands for \$29,000.00. Overall cost per Veteran from Dominion Command and Provincial Commands combined would be \$600.00 per Veteran.

The P&R Committee reviewed this requirement and was satisfied that the request met the requirements for the use of Poppy Funds.

RECOMMENDATION: It was recommended that \$25,000 be allocated from Poppy Funds to support the work in 2019 of Project Healing Waters

QUINISM FOUNDATION TO CONDUCT MEFLOQUINE RESEARCH

At the VSS Committee meeting on 24 November 2018, the Committee reviewed a request for funding for \$25,000 to The QUINISM Foundation to conduct Mefloquine research.

This review included the proposal, discussion involved around the recruitment of the Veterans for the study, credibility of the study, that the results have to withstand scrutiny, links to CIMVHR and the availability of the medical records through our Canadian Privacy Act. After discussion, the Committee concurred with the proposal.

The P&R Committee reviewed this requirement and was satisfied that the request met the requirements for the use of Poppy Funds.

RECOMMENDATION: It was recommended that \$25,000.00 be allocated to fund the Mefloquine research to The QUINISM Foundation from the Dominion Command Poppy Trust Fund.

PROJECT TRAUMA SUPPORT

At the last VSS Committee meeting on 13 February 2019, the Committee reviewed a proposal from Project Trauma Support.

Project Trauma Support (PTS) provides a small group, six-day residential healing program that focuses on post-traumatic growth. It provides an opportunity for healing and growth at a much lower cost than traditional methods. The program requires additional funding to support candidates (attendance and travel) so that there can be sufficient data collection to validate the success. Once success has been demonstrated (approx three years), PTS will be in a position to be granted "provider status" with Blue Cross/Medavie and will then be eligible to bill VAC directly for services rendered. Without funding, this successful program will, in all likelihood, collapse and the opportunity will be missed.

The P&R Committee reviewed this requirement and was satisfied that the request met the requirements for the use of Poppy Funds.

RECOMMENDATION: It was recommended that \$300,000.00 be allocated to Project Trauma Support; \$100,000 on an annual basis for three years – total of \$300,000 from the Dominion Command Poppy Trust Fund with the caveat that funding for years two and three will be contingent on receiving an annual accounting and report of expenditures prior to requesting ratification by DEC in years two and three.

LEGION HOMELESS VETERANS STRATEGY AND PROGRAM GUIDELINES

The VSS Homeless Veterans representative is developing a Legion Veterans Homelessness Strategy; it is currently in draft form and will be presented at the DEC in November 2019. Currently, Homeless Veterans Program Guidelines were developed, and are attached to the report for your review. The Guidelines were developed for Commands to either adopt or use to improve their already existing Leave the Streets Behind Program. I would like to DEC to approve the Guidelines and the Committee will distribute to the Commands. They are not mandatory, it is a Guide to assist our

Commands.

RECOMMENDATION: It was recommended that the Homeless Veterans Program Guidelines be approved and disseminated to Provincial Commands for assistance in developing a Leave the Streets Behind Program or to use to improve their already existing program.

OUTREACH AND VISITATION INITIATIVE PROGRAM

The current contract was renewed on 1 October 2018 for the next two years, to visit 5,000 Veterans each year. There have been 122 taskings to visit 2,642 Veterans in Long Term Care (LTC); our volunteers completed 1,548 visits to date.

DOMINION COMMAND VETERANS SERVICES

A Command Service Officer course was conducted from 2-4 April 2019 at Legion House, 13 students in attendance. Dominion Command Veterans Services provides mentorship and guidance, not only to the new Service Officers but also for all Command Service Officers.

Dominion Command Service Officers continue to experience a significant increase in the complex and multi-condition applications. There is a significant increase in still-serving RCMP and military still-serving applications for DC Service Officers:

	2014	2015	2016	2017	2018
Benevolent	375	439	430	410	380
First Application/ DR	273	310	374	266	223
VRAB Appeals	207	133	51	56	16

Veterans Services counselled out 90 applications/Appeals during 2018.

FIRST APPLICATIONS AND DEPARTMENTAL REVIEWS

The overall First Applications and Departmental Reviews prepared and submitted by Legion Command Service Officers have increased this year and we are seeing an unprecedented number of multi-condition claims. While the claims from the traditional Veteran population are declining, there is an increase of claims by post-Korean Veterans, including still serving CAF and RCMP members. Overall, 20.4% were related to still-serving members, 43.9% retired military, 0.7 Reservists and 35% related to RCMP service.

	2014	2015	2016	2017	2018
Total First Application Claims submitted by RCL	2511	2971	2522	2765	3119
Departmental Reviews submitted by RCL	158	155	144	151	552
Total/Claims Withdrawn/Counselled Out	518	321	644	858	1153
Total Claims Handled by RCL	3187	3,463	3,524	3,774	4,824

Comprehensive statistics for all Command Service Officers are attached to this report.

VETERANS REVIEW AND APPEAL BOARD

VRAB Reviews are conducted across the country with Command Service Officers co-representing with the Bureau of Pensions Advocates. Appeals and Reconsiderations continue to be heard at Legion House with representation from Dominion Command Service Officers.

	2014	2015	2016	2017	2018
Total VRAB Reviews	375	165	163	167	83
Total VRAB/RfR Appeals	207	152	51	56	16
Total VRAB Cases Handled by RCL	582	317	214	223	99

Note: VRAB Entitlement Appeals are down considerably for 2018 due to the high number of Appeals counselled out at Dominion Command.

BENEVOLENT REQUESTS

Requests for benevolent fund assistance decreased to 380 being processed by the Dominion Command Veterans Services in 2018, compared to 410 in 2017. The following table outlines our benevolent efforts for the various funds and provides a snapshot of Dominion Command's efforts over the past three years.

FUND	2016		2017		2018	
	NO OF CASES	AMOUNT	NO OF CASES	AMOUNT	NO OF CASES	AMOUNT
POPPY	114	\$91,331.41	96	\$73,491.70	76	\$77,652.93
SCOWP	22	\$13,267.18	25	\$12,530.34	21	\$13,908.81
RAFBF	119	\$113,782.43	116	\$100,273.04	129	\$96,207.02
RNBTF	28	\$27,180.32	12	\$10,880.28	22	\$26,868.51
UK Regimental	147	\$180,938.81	161	\$208,285.93	132	\$162,931.20
TOTAL	430	\$426,500.15	410	\$405,461.29	380	\$377,568.47

POPPY: Poppy Benevolent Fund
 SCOWP: Standing Committee on Welfare Payments (RCEL)
 RAFBF: Royal Air Force Benevolent Fund
 RNBTF: Royal Navy Benevolent Trust Fund

PROVINCIAL VSS REPORTS – RESPONSE AND HIGHLIGHTS

Provincial VSS reports will be presented in April 2020.

CONCLUSION

This is my report and I move its adoption.

**ROYAL CANADIAN LEGION
DOMINION COMMAND
LEAVE THE STREETS BEHIND
HOMELESS VETERANS PROGRAM GUIDELINES
FOR PROVINCIAL COMMANDS AND LEGION BRANCHES**

The following guidelines are to assist Provincial Commands and Legion Branches to establish a Homeless Veterans program in their respective areas. They are not steadfast or mandatory but are meant to provide assistance to establishing a Homeless Veterans program.

Veterans Services and Seniors/Homeless Veterans Committee

Since the beginning of the program there has been no stipulation to the makeup of the VSS or Homeless Veterans Committee(s). Is the Homeless Veterans Committee part of the VSS Committee or is it a separate identity? The decision is that of Provincial Commands, but there must be consistency throughout the Districts, Zones and Branches as they will continue to implement the program.

DEFINITIONS

Understanding the types of Homelessness is a must and can determine how each case will be handled.

Absolute Homelessness

Absolute Homelessness is defined where an individual or family has no permanent housing and is staying in temporary shelter. The temporary shelter could be doorways, empty buildings, abandoned vehicles, parks or bench common areas.

Near Homelessness

An individual or family are on the brink of losing their present living quarters, due to lack of payment of rent, heat and hydro, etc.

At Risk Homeless

An individual who is dependent on others for housing, who is couch surfing, and whose personal or economic situation has changed.

NOTE

Keep in mind that Female Veterans have been identified in the Homeless Veterans program.

GETTING STARTED

Appoint a Committee Chairman and establish a committee. Develop Terms of Reference for the committee and determine who will be responsible for the various aspects of the program.

Keeping statistics is extremely helpful as they will give credibility to future reports and updates to various organizations, VAC and other government agencies, and itemize the assistance provided.

Identify and create partnerships with various Missions and Shelters, Police, EMS, VAC and create a referral to where these associations can make contact with the VSS Committee or Command office to engage in a solution or assistance for the Homeless Veteran.

Develop literature for the program and distribute to various partners.

It is essential that VAC be a partner in your program. Once you have received documentation, provide the local VAC office with a copy and ensure the Veteran becomes a client and they look after any paperwork for benefits to which they may be eligible to receive. Have a meeting with the local offices or the Command can meet with the Regional Director General to ensure VAC is on board with the program.

FUNDING

Dominion Command approved the use of Poppy Funds in 2010, thus eliminating the necessity for Provincial Commands or Branches to use funds from the General Account to support the Homeless Program. Branches can donate to a Homeless Veterans Fund created at the Command level and these funds can be used to support the program and pay necessary expenses for meetings and support being given to the Veterans. Reference Poppy Manual, page 23, Section 402 (v) iii.

Many Branches have noted there are no Homeless Veterans in their communities; this does not mean that they cannot donate to the Provincial Command Homeless Veterans Fund to support the program. Many Branches have excess funds in their Poppy accounts and this is an ideal way to use them, when it is least expected a Veteran could find themselves in a bad situation. Commands can also donate to the Dominion Command National Foundation, whereby funds could be used to assist other Commands who are short on funding for this program.

PAPERWORK

It is essential to create a document that identifies the Veteran when they apply for assistance. Attached is a simple one-page document that will provide his/her name, contact information for the Shelter and their Case Workers name. Please put the document on your respective Command letterhead. Also noted and the most important is the Service Number, we cannot emphasize the necessity for this information. Before any assistance is provided it is **mandatory** to verify the

Service of the Veteran, this can be done through VAC. This verification is necessary, as there are many people coming forward claiming they are Veterans and seeking assistance through the Homeless program. Completing this form will also allow for a paper trail and will avoid duplication. In the past, we have found that people have attempted to use the Homeless fund for travel across Canada indicating they are Homeless and asking Branches for funds for travel, noting they have to get to another city or town to visit a sick family member. A paper trail will avoid such duplication.

PROVIDING ASSISTANCE

Once verification is complete, the need of the Veteran should be first and foremost. What are the immediate needs? Gift cards purchased locally can provide food, clothing etc.

Never give cash or a cheque to an applicant! Commands and Branches can purchase gift cards, for example from Tim Hortons, McDonald's, Walmart or local grocery stores. In doing so, the Veteran is limited to what he/she can purchase with the card and this eliminates alcohol etc.

Providing assistance for new accommodation, in the manner of first and last month's rent, caution must be taken to ensure that the Veteran can sustain the costs of the apartment. Before committing to any funds request a copy of the Lease Agreement and a financial update from the Veteran to ensure they can afford the unit. **Make cheques payable to the Landlord and send directly to them, and DO NOT put the Veterans name on the cheque.**

If possible, provide an apartment kit or something to welcome the Veteran to their new home. A set of dinnerware, cutlery, coffee mugs cups and saucers, drinking glasses, dish soap, dish clothes, and the list goes on. See list below. Back Packs can also be used to encourage Homeless Veterans to seek the assistance they require to Leave the Streets Behind. See the list below. These backpacks can be given to VAC to assist in encouraging the more cautious Veterans to come forward.

Community Assistance

Once you let the community know that the Homeless Veterans program exists, they will come forward with assistance and will make inquiries as to what is needed. You may be overwhelmed by the assistance that various community groups and organizations will bring forward. Be sure to let the community know what the Legion is doing to support the program and assistance being given to the Homeless Veterans in your area.

As previously noted the information provided is a Guide only, and from this Legion Commands and Branches can develop their own Homeless Veterans program.

If you have questions or require clarification and further information, please contact Comrade Ray McInnis, Secretary, VSS Committee, Dominion Command, rmcinnis@legion.ca.

Apartment Kit

Salt/pepper, Shower curtain + rings, 8 piece bed in a bag, Pillows, Afghan, Tide, Pot/pan set,

Garbage & compost bags, Plastic container set, Spatula, large spoon, flipper set(5 pieces), Cutlery set, Dishes, coffee mugs, Drinking glasses, Dish towels, Wash cloths, Dish soap, all-purpose cleaner and wipes, Alarm clock, Paring knife, Carrot/veggie peeler, Tongs, Toilet paper, Paper towel, Bath towel set, Electric kettle, Toaster, Hangers, Coffee/hot chocolate packs, Instant oatmeal

Comfort Bag (Backpack)

Ground matt, 2 in 1 shampoo, Sun screen, Deodorant, Tooth brush/paste, Floss, Bar of soap and holder, Wash cloth, Nail cutter set, Passport pouch, Chap stick, Hand/foot warmers, 2 pairs of socks, T- shirt, Candies, Instant oatmeal, Coffee/hot chocolate, Small chocolate bar, Can of nuts, Winter socks, First aid kit, Hat/mitt/scarf, Baseball hat, Pen & paper, Hand wipes, Combs/hair brush, Hand cream



Veterans Affairs
Canada

Anciens Combattants
Canada

ANNEX "F" TO
DEC MINUTES
13-14 APRIL 2019



OPERATION – LEAVE THE STREETS BEHIND
ROYAL CANADIAN LEGION
VETERANS AFFAIRS CANADA
HOMELESS VETERANS ASSISTANCE PROGRAM

**REQUEST FOR ASSISTANCE
And
RELEASE OF INFORMATION**

Date: _____

Name: _____ Service No. _____

Date of Birth: _____

Shelter Name and Address: _____

Shelter Contact: _____ tele# _____

Nature of Assistance Required: _____

I _____, authorize the Royal Canadian Legion
Please print
and/or Veterans Affairs Canada to access all medical and service records, including those held by the National Archives of Canada, for the purpose of applying for services and benefits through any agency of Veterans Affairs Canada.

Signature

Please fax to: 905-841-9992
Royal Canadian Legion Ontario Provincial Command





Veterans Affairs
Canada

Anciens Combattants
Canada



Homeless Veterans Assistance Fund- Request for Funds

Name:

Service/File#

Current Address:

Telephone Number:

cell yes No

Contact name, address and telephone:

Service:

Amount required: \$

Case Manager Name:

District Office:

Telephone #:

Assistance Required and Funding Rationale:

Fax to:

The Assistant Executive Director
Royal Canadian Legion
905-841-9992

Canada

Command Services Officer's Stats		Last Updated	15 Mar 19 - 07:52	VRAB					
Command	1st APP	DR	Counselled Out/Withdrawn	FWD DC	ER	EA/RfR	WI VIP/PME	SCAN /Field Visits Info	
BC / Yukon		131	12	19	5	0	0	42	4
	Totals	131	12	19	5	0	0	42	4
Alta / NWT		683	40	252	15	0	0	78	8
	Totals	683	40	252	15	0	0	78	8
Sask		15	7	13	3	1	0	5	20
	Totals	15	7	13	3	1	0	5	0
Man / NW Ont		24	7	10	0	0	0	1	3
	Totals	24	7	10	0	0	0	1	0
Ont		1348	317	371	68	76	0	804	295
	Totals	1348	317	371	58	76	0	804	295
Que		135	14	86	2	2	0	35	19
	Totals	135	14	86	2	2	0	35	19
NB		240	33	182	9	1	0	84	6
	Totals	240	33	182	9	1	0	84	6
NS / NUN		362	37	125	0	0	0	52	3
	Totals	362	37	125	0	0	0	52	3
PEI		10	3	0	0	1	0	0	15
	Totals	10	3	0	0	1	0	0	15
NFLD / LAB		28	2	5	2	2	0	3	1
	Totals	28	2	5	2	2	0	3	0
DOM COMD		143	80	90	0	0	16	100	20
	Totals	143	80	90	0	0	16	100	20
Grand Total		3119	552	1153	94	83	16	1204	370

DR: Departmental Review

VRAB Revies that you attend as co-rep with BPA

WI: VIP / PME: Work Items Sent for Veterans Independence Program / Reassessments/Address Changes

SCAN: Second Career Assistance Network/Actual Field Visits to Branches

FWD DC - VRAB 9s sent to DC for Entitlement Appeals and Request for Reconsiderations

**REPORT OF THE DOMINION COMMAND
POPPY AND REMEMBRANCE COMMITTEE
TO THE DOMINION EXECUTIVE COUNCIL
13-14 APRIL 2019**

File: 35-1

B. Lawrence	-	Vice-Chairman
L. Varga	-	Member
J. Ladouceur	-	Member
K. Merola	-	Member
G. Hodge	-	Member
D. Martin	-	Facilitator
K. Therien	-	Asst Facilitator

GENERAL

The Poppy and Remembrance Committee last met on 13 February 2019 via teleconference.

RECOMMENDATIONS FOR DEC CONSIDERATION

The following recommendations were made by the committee at the 13 February teleconference. In the interest of brevity only the recommendations are listed. The detail is contained in the committee report of 13 February 2019.

a. 2019 PILGRIMAGE OF REMEMBRANCE – PIPER POSITION

RECOMMENDATION: That the Legion Foundation add a Piper position to the Pilgrimage of Remembrance.

b. MODIFICATIONS TO THE COMMITTEE’S TERMS OF REFERENCE AND PROGRAM DESCRIPTION – LEGION NATIONAL FOUNDATION

RECOMMENDATION: That the Legion Poppy & Remembrance Committee’s Terms of Reference is modified to reflect the relationship between the committee and the Legion National Foundation by adding the following:

“On behalf of the Legion National Foundation manage as well as propose recommendations or amendments to policy concerning:

- i. the parts of the Legion literary and poster remembrance contests for children and youth that are conducted at the national level;
- ii. revisions to the Legion Teaching Guide for Children and Youth;
- and
- iii. the Pilgrimage of Remembrance. “

c. **THE NATIONAL POPPY FUND – REQUIREMENT TO PROVIDE A STANDARD APPLICATION PROCESS**

RECOMMENDATION: That the Legion adopt a formalized process at the national level to include the guidelines, application, partnership agreement and final report as outlined in the attachments listed above.

d. **REQUEST FOR POPPY FUNDS – INTERNAL- RECOMMENDED**

i. **RECOMMENDATION:** That DEC approve the use of Dominion Command Poppy Trust Funds in the amount of \$30,000 to support the Poppy Drop initiative.

ii. **RECOMMENDATION:** That \$30,000 be allocated from Poppy Funds to support the 2019 Digital Poppy marketing plan.

e. **REQUEST FOR POPPY FUNDS – EXTERNAL - RECOMMENDED**

i. **RECOMMENDATION:** That \$25,000 be allocated from Poppy Funds to support the work in 2019 of Project Healing Waters.

ii. **RECOMMENDATION:** That \$90,000 be allocated from Poppy Funds to support the the RCL Masters Scholarship for another three-year cycle, starting in 2020-2021 ending in 2022-2023.

iii. **RECOMMENDATION:** It is recommended that the funding request for \$25,000.00 to fund the Mefloquine research be provided to The QUINISM Foundation from the Dominion Command Poppy Trust Fund.

iv. **RECOMMENDATION:** It is recommended that the funding request from Project Trauma Support for \$100,000 on an annual basis for three years – total of \$300,000 from the Dominion Command Poppy Trust Fund be approved with the caveat that funding for years two and three will be contingent on receiving an annual accounting and report of expenditures prior to requesting ratification by DEC in year two and three.

f. **REQUEST FOR POPPY FUNDS – EXTERNAL – NOT RECOMMENDED**

RECOMMENDATION: Based on the information provided and in accordance with the rules governing the use of Poppy Funds the committee did not recommend the use of Poppy Funds for the Soldier On sponsorship request

g. **POPPY FUNDS – DONATION OPTION FOR BRANCHES**

RECOMMENDATION: To create a national repository for Poppy Funds to allow branches to donate to authorized causes.

h. **THE DIGITAL POPPY –
RETENTION OF FUNDS AT THE NATIONAL LEVEL**

RECOMMENDATION: That Digital Poppy Funds be retained at Dominion Command as part of the national Poppy Fund with an option for use in local communities where a need exists for veteran support and local/provincial Poppy Funds are not adequate to support the request.

i. **THE POPPY MANUAL: AREAS FOR DISCUSSION**

- i. **RECOMMENDATION:** Revise article 403.ii.d. to state: Veteran Services: (prior Provincial Command approval is required) 50 percent of the current balance, for support of Legion Branch drop-in centers or facilities that support Veterans services only as long as these provide known support to Veterans in the community.
- ii. **RECOMMENDATION:** Revise article 402.vi.a. to state: the granting of bursaries to students who are Veterans, a lineal descendant or a collateral descendant (see definition section) of the eligible personnel as identified in Section 401 of this manual; who are in need of financial assistance. Bursaries may be awarded at any stage of a college or university program. The use of Poppy Trust Funds for Scholarships is NOT authorized.
- iii. **RECOMMENDATION:** Revise article 402.vi.d. to state: Poppy Funds can only be used for monetary awards for the top three placements in each category of the Poster and Literary contest and those awards do not exceed those amounts given at the national level.
- iv. **RECOMMENDATION:** Revise article 403.ii.f. to state: Monuments: (prior Provincial Command approval is required) 25 percent of the current balance, for the purpose of constructing, maintaining or preserving local monuments to Veterans. The 25 percent must not exceed one half of the total funds (50 percent) required to construct, maintain or preserve local monuments for which funds are allocated. For Legion owned monuments 50 percent of the current balance may be used for the purpose of constructing, maintaining or preserving the monument.

- i. **RECOMMENDATION:** Remove article 815.i. (Personal Tattoos) from the Poppy Manual.
- ii. **RECOMMENDATION:** Modify article 501.iv.f: to read – “general or non-specific donations to charities, registered or non-registered, or not for profits that do not meet the criteria listed in Sections 401, 402 or 403 of this manual. Examples include, Heart and Stroke Foundation, Canadian Cancer Society, March of Dimes, non-Legion administered Food Banks, etc or for administrative or operational expenses of any organization. When in doubt, contact your provincial command for direction.
- iii. **RECOMMENDATION:** Modify article 403.ii.h. to read: Annual Veterans Visit: (prior Provincial Command approval is required) Up to \$25.00 per meal, per Veteran/spouse, to provide an annual visit to branches and/or when not feasible due to the age/condition of the veterans, to also host in a convenient location both for the Veterans and a spouse/ caregiver who is accompanying a Veteran, or a Veteran’s widower/widow accompanied by a caregiver to offer a meal and camaraderie. The amount is authorized from Poppy Trust Funds to cover the cost of the meal only and must not include the cost of any alcoholic beverages or other services, such as entertainment. Details of the event and receipts must be submitted after the event.

j. **ANIMALS OF WAR – RECOGNITION (UPDT)**

RECOMMENDATION: That the Legion introduce a memorial symbol to recognize the sacrifices made by “Animals of War” with funds collected to be directed towards the recognition of the animal/veteran relationship.

k. **DONATING POPPY FUNDS TO CAUSES
ATTEMPTING TO RAISE FUNDS (I.E. MONUMENT PROJECTS)**

RECOMMENDATION: Modify article 403.ii.f. to read: Monuments: (prior Provincial Command approval is required) 25 percent of the current balance, for a one time contribution for the purpose of constructing monuments to Veterans and 25 percent of the current balance for maintaining or preserving local monuments to Veterans. The 25 percent must not exceed one-half of the total funds (50 percent) required to construct, maintain or preserve local monuments

for which funds are allocated.

I. **VELCRO POPPY**

RECOMMENDATION: Produce a formalized agreement to allow Urban Tactical to produce and distribute the Velcro Poppy.

CONCLUSION

The next Poppy & Remembrance meeting is scheduled for Legion House in Nov 19.

In the absence of questions or discussion, I move acceptance of this report.

Angus Stanfield
Chairman, Poppy & Remembrance Committee

Date: 5 April 19

File: 35-1

**ADDENDUM TO REPORT OF THE DOMINION COMMAND POPPY &
REMEMBRANCE COMMITTEE TO DOMINION EXECUTIVE COUNCIL 13-14 APRIL
19**

As the Poppy & Remembrance Committee met on 13 Feb 19 the following was not included on the original report to DEC. For DEC consideration.

The Committee Secretary met with a company called Avrio at their request in regard to using digital donation specific terminals designed for countertops. The attached gives an indication of what it looks like and how it works. Basically it can be designed to accept cash donations and digital donations. The cost to operate is very reasonable and the terminals are rented, enabled and administratively hooked up by Avrio. Although we are not prepared at this time, as an organization, to accept this mode of donation it is the way of the future as we slowly approach a cashless society.

Based on the discussions during the briefing it was agreed as a first step to have a trial conducted (say in Ottawa) where approx. 20 machines would be deployed during the Poppy Campaign at a common location (say Tim Hortons or BMO) in order to gauge the feasibility of a wider implementation of this type of collection method.

Therefore what is being requested is the authority to conduct a limited trial of a cashless payment device for the 2019 Poppy Campaign. The recommendation is as follows:

RECOMMENDATION: That the Poppy & Remembrance Committee be given the authority to proceed with a limited trial during the Poppy Campaign in 2019 using the Avrio cashless devices.

Collect 100% of the time!

- Simple
- Affordable
- Autonomous collection points
- Universal digital acceptance



Affordability and Ease of Use.

Royal Canadian Legion – Concepts for Poppy Box

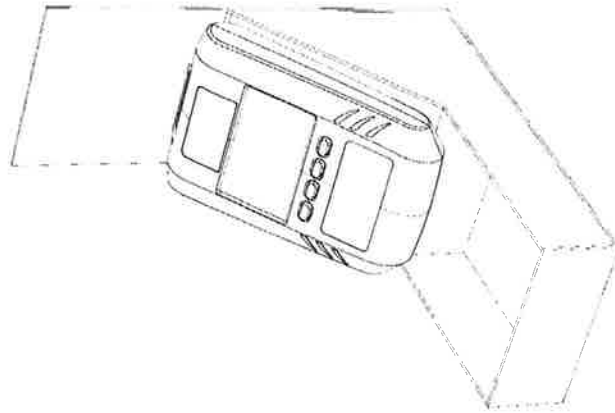
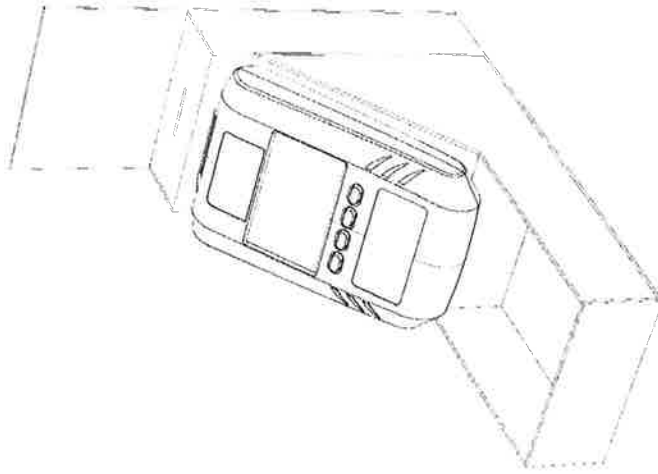
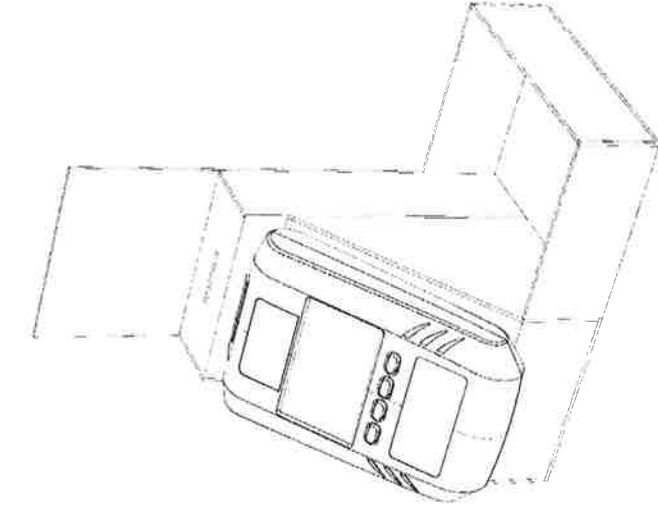

**REPORT OF THE DOMINION COMMAND
MEMBERSHIP COMMITTEE
TO THE DOMINION EXECUTIVE COUNCIL
13-14 APRIL 2019**

File 23:1

Bruce Julian	-	Chairman
Valerie MacGregor	-	Vice-Chairman
Terry Campbell	-	Member
Duane MacEwen	-	Member
Garry Pond	-	Member
Randy Hayley	-	Committee Facilitator
Danny Martin	-	Asst. Committee Facilitator

GENERAL

This report covers the period from November 01, 2018 to March 11, 2019. During this period, the Membership Committee convened on three occasions. Twice via teleconference and once in person.

2019 MEMBERSHIP NUMBERS

As of March 08, 2019:

- 204,368 Total Paid Membership - down 6,400 members or 2.7% year over year
- Renewals at 72.1% compared to 73.7% at the same time last year
- 13,240 New Members enrolled for 2019 – up 2,200 members or 21% year over year (including the Veterans Welcome Program)
- 1,400 Veteran Welcome free 1-year membership sign ups
- 883 members deceased compared to 975 at the same time the year before.

Key performance indicators for the membership website continue to progress positively and are distributed weekly in the Member Services update report.

NATIONAL RENEWAL STRATEGY FOR BRANCHES

With the Member Services strategic plan firmly established as our administrative foundation the Membership Committee has developed a National Member Renewal Strategy for Branches and has established national renewal targets. These targets will be segmented by command for 2019. Monthly updates on these targets to be shared with each provincial command.

The strategy requires active participation from all levels within the Royal Canadian Legion including Branches, Provincial Commands, Dominion Command and Legion House as

our success is 100% reliant upon increased participation from all. The committee has created 5 easy steps to improve member renewal and retention rates and has assigned the word RENEW as an appropriate acronym in defining the key pillars of the strategy (see handout). This strategy will be reviewed at all upcoming Provincial Conventions in a standardized presentation.

INCREASING MEMBERSHIP

Along with the renewal strategy for branches, the committee encourages all commands to ensure discussions surrounding increasing membership and further streamlining procedures are at the forefront of all upcoming conventions.

The committee has discussed some of the long-standing procedural impediments to attracting new members with no current consensus on solutions. The committee fully recognizes further refinements will be required if we are to obtain our lofty membership goals of 300,000 members by 2026.

SUMMARY

Building on measurable successes in 2018 the committee continues to move forward in this new era for Legion membership and looks forward to implementing the next phase of our membership strategy.



Branch Membership Renewal STRATEGY

R

RENEWAL reminders

- Personal phone calls yield best results
- Email reminders
- Direct mail reminders

40%

of non renewing members **did not remember** receiving a renewal reminder

E

EMAIL addresses

Collecting and entering member email addresses within the member services website allows both the Branch and Legion House the ability to send important reminder notices electronically.

N

NEVER again ask members to renew with Auto Renewal

Auto Renewal automatically renews members annually who have signed up online with a credit card. Branches save time and money. No processing or paperwork required from the Branch.

Please consider: Each time we ask a member to renew, we are asking them to reconsider if they still want to be a Legion member.

E

ELECTRONIC renewal saves time and money for both Branches and Members

Ensure your Branch rate is entered in the member services website to allow your members the opportunity to renew online providing another option for renewal.

41%

of non-renewing members **would renew online**

W

WELCOME all with improved Branch hospitality

Review the Branch Hospitality Program

25%

of non-renewing members found their Branch **experience to be un hospitable**

MEMBER SERVICES WEBSITE PROCESSING

To ensure Branches are always using the most up-to-date membership information we encourage Branches to process all members using the member services website. Not only does this ensure up-to-date member information, but it also improves accuracy and saves time and money while providing improved customer service to all.

MEMBER SERVICES | MEMBERSHIP@LEGION.CA | 1-855-330-3344



2019 Membership Committee Targets

<u>CATEGORY</u>	<u>2019 TARGET</u>
RENEWALS	88.5%
BRANCH RATES	95% 1325 Branches
MEMBER EMAILS	35% 100,000 Members
BRANCH PORTAL PROCESSING	60% 840 Branches
AUTO RENEWALS	3% 8,000 Members

**REPORT OF THE DOMINION COMMAND
SPORTS COMMITTEE
TO THE DOMINION EXECUTIVE COUNCIL
13-14 APRIL 2019**

File: 42-2

Brian Weaver	-	Chairman
Dave Flannigan	-	Vice Chairman
Jerry Lava	-	Member
Keith Andrews	-	Member
LeRoy Washburn	-	Member
Melvin Crowe	-	Member
Lia Taha Cheng	-	Committee Facilitator
Angela Colkitt	-	Assistant Committee Facilitator

GENERAL

This report covers the period from 1 November 2018 to 15 March 2019. The committee last met on 24 November 2018 at Legion House and as part of a national sports teleconference on 4 February 2019.

DOMINION MEMBER SPORTS CHAMPIONSHIPS ELIGIBILITY

The committee discussed the items below and concluded that these three eligibility concerns require input from the Membership Committee, Constitution and Laws Committee and Dominion Executive Council:

a. Member in Good Standing

Dominion Member Sports Championships are open to members as defined in the General By-Laws of The Royal Canadian Legion. To be eligible, members must be in good standing and should have their membership card for the year in which the championship is being held in their possession at the site of the championship. Member in good standing means a member who is not under suspension or is not in arrears in payment of dues.

It was discussed that a member becomes a member in good standing as soon as they pay their dues; therefore, it does not have to be before 31 January. January 31 is only applicable when a member transfers from another branch.

b. Member Initiation

The Membership Application states: "Congratulations you are now an initiated member of the Royal Canadian Legion subject to Branch policy. Further welcoming ceremony processes are at the discretion of your local Branch."

The will of the Membership Committee was to allow branches to maintain their autonomy and continue with the traditional swearing in ceremony if they so wished. That said, to expedite the process of new members joining the Legion, the traditional swearing in ceremony is now optional and not required by the Branch.

The committee discussed the need for consistency between branches, as some branches require individuals to be accepted by the branch before they can become a member, which can take a considerable amount of time.

c. Volunteer Hours

Branches may opt to institute a required minimum number of volunteer hours in order to qualify for funding to participate at the National level. In addition, for general play at the branch level, the branch itself can dictate who is eligible and/or under what requirements are needed to participate. However, it should be noted that any member in good standing is eligible to participate in a branch sports activity that is a qualifier for a Dominion Sports Championship. Therefore, if a branch were hosting a qualifier to progress to the Dominion level for Darts, Cribbage or Eight Ball, any member in good standing would be entitled to participate with no branch imposed restrictions.

PROPOSED SPORTS GUIDE AMENDMENT – SPORTS GUIDE 707

The intent of this amendment is to ensure that the Legion Nationals coaching criteria are consistent with the National Coaching Certification Program (NCCP) standards and Athletics Canada requirements.

As per section 707 of the current Sports Guide, the criteria for coaches are as follows:

- b. Each Provincial Command must name one coach as the Head Coach and that person should be fully certified at Level 3. All remaining team coaches should require a Level 2 certification. There may be exceptions to this rule; and
- c. Each provincial athletic association is permitted to designate no more than two additional coaches of Level 1 or 2 to accompany their team for certification purposes.

In the last 10 years, the NCCP has transitioned away from delivering Level 1, 2, and 3 programming. The Levels-NCCP system has been replaced by coach training opportunities that are grouped into three main streams: Competition, Instruction, and Community Sport.

Specific to track and field, Level 3 has been replaced with Performance Coach, Level 2 has been replaced with Club Coach, and Level 1 has been replaced with Sport Coach. Upon consultation with the Athletics Canada Coaching Advisory Council, replacing each level with their respective new designation would not be appropriate for the age group and long-term athlete development (LTAD) stage of Legion Nationals athletes. The Athletics Canada website states: "The Performance Coach certification is for coaches

who are coaching year round, 40 or more weeks a year and 5-10 sessions a week. The athletes they are responsible for are competing at the national level in the junior or senior categories. The training for this course is event group focused. The main focus of this course is annual planning and periodization." Note the reference to "junior and senior" categories, not youth, as for Legion Nationals athletes.

Since Athletics Canada's Performance Coach Certification is required for coaches who are working with U20 or older athletes, the following recommendations are brought forward for DEC consideration and approval:

RECOMMENDATION: It is recommended that section 707b of the Sports Guide be amended to read: "Each Provincial Command must name one coach as the Head Coach and that *person has to be a fully certified National Coaching Certification Program (NCCP) club coach. All other team coaches require NCCP club coach trained certification.* There may be exceptions to this rule."

RECOMMENDATION: It is recommended that section 707c of the Sports Guide be amended to read: "Each provincial athletic association is permitted to designate no more than two additional *NCCP club or sport trained coaches* to accompany their team *for professional development purposes.*"

CONCLUSION

The Sports Committee's next meeting will be scheduled as a teleconference. The exact date has yet to be determined.

I move acceptance of this report as presented.

**REPORT OF THE DOMINION COMMAND
PUBLIC RELATIONS COMMITTEE
TO THE DOMINION EXECUTIVE COUNCIL
13-14 APRIL 2019**

Owen Parkhouse	-	Chairman
Sharon McKeown	-	Vice-Chairman
Stephen Gallant	-	Member
Nathan Lehr	-	Member
Kenneth Ouellet	-	Member
Chris Strong	-	Member
Nujma Bond	-	Committee Facilitator
Dion Edmonds	-	Ass't Committee Facilitator
Leah O'Neill	-	Ass't Committee Facilitator

OVERVIEW

The committee met once in late November, after which a report addendum was created for DEC. As of this writing, the committee plans to meet again in early April.

In the wake of the relatively steady period after the Remembrance period, the climate changed in February. The change in leadership at Veterans Affairs Canada drew attention to the Legion, both in terms of media asking for our views, and in the because of a statement issued at the national level.

The output of public relations tools and initiatives also continued throughout the past few months and some highlights are included below.

HIGHLIGHTS

Public relations activities:

- Issued Legion statement related to the constant change in Veterans Affairs Canada ministers over the past years.
- Issued Legion statement to welcome the newest VAC minister.
- Prepared presentation details for Legion Dominion President's remarks to Senate Subcommittee meeting on VAC leadership change.
- Created draft advocacy position paper based on Legion focus areas, and timely new issues.
- Shared information update on Stolen Valour for online and internal use.
- Released an updated new video outlining the significance of the poppy - from how it became the Legion's symbol of Remembrance, to what happens to the Poppy Funds collected.
- Held PR training day for Provincial Executive Directors in late November.

- Created national scope op-ed, published in the Ottawa Citizen related to veterans and operational stress injuries. Highlighted work of the Legion and The Mental Health Commission of Canada, whose former Vice Chair co-authored the piece.
- Completed Legion 2018 Year in Review piece for Legion magazine's March issue, also posted online.
- Issued monthly PRO (Public Relations Officer) Update reports to help keep PR colleagues informed.
- Handled national scope media interviews. Topics included the change in VAC ministers, wait times for handling of disability claims, the length of time it's taking to complete a national Afghanistan monument in Ottawa, and the Parliamentary Budget Officer's report showing veterans more severely injured may receive less financially when Pension for Life kicks in.
- Handled ongoing questions and complaints within our public feedback and social media channels; we continue to see a noticeable reduction in negative feedback.
- Supported the Legion's National Silver Cross mother in a personal presentation made at CFB Moose Jaw - 17 Wing.

PRO meeting discussions:

- Meetings in December, January and March allowed PROs from across the country to discuss a range of issues and update others on regional activities.

MOVING FORWARD

New projects and strategic discussions in the weeks and months to come include:

- (At time of writing: preparation of a news release related to the Federal Government's 2019 budget set for March 19.)
- Updated language and articles/background related to Stolen Valour, and to the ongoing need for modern military equipment and training for our armed forces.
- Discussion of possible Legion participation/PR-related activities related to National Tulip Festival 2019.
- Ongoing: helping to fill the communications gaps at the Branch level, PR training, short informational videos, media tools.

I move acceptance of this report as presented.



Emergent Issues Process
Public Relations Committee

Dominion Command AM meeting or during the day

Issue is identified that requires immediate response



PR Committee Secretary

Issues email to committee members
Calls short phone meeting if appropriate
Describes issue and possible Legion reply
Indicates timeline for response



PR Committee Members

Review reply or position statement
Offer comments or alternative action ideas



PR Committee Secretary

Sends position or statement to Dominion President for agreement

Distributes to DEC and EDs for information
Prepares for proactive or reactive public dissemination
Distributes to PROs

**REPORT OF THE DOMINION COMMAND
RITUAL AND AWARDS COMMITTEE
TO THE DOMINION EXECUTIVE COUNCIL
13-14 APRIL 2019**

Ken Sorrenti	- Chairman
Blaine Kiley	- Vice-Chairman
Mary-Ann Latimer	- Member
Paul "Smokie" LeBlanc	- Member
John Cher	- Member
Joel Van Snick	- Member
Denis Hotte	- Facilitator
Charls Gendron	- Assistant Facilitator

COMMITTEE ACTIVITY

The Ritual and Awards Committee last reported to D.E.C. on November 24th, 2018. The Committee has met four times since then. One of these meetings was at Legion House, one was conducted electronically and two were teleconference meetings. Applications for major awards were reviewed in a timely manner and all matters pertaining to Ritual, Awards, and Protocol were attended to. There is no backlog of applications. The Committee has noted an increase in the number of enquiries being received concerning Ritual, Awards and Protocol, but all are addressed in a timely manner.

THE R.A.P. MANUAL

Since the convention in August, Committee members undertook the task of reviewing the manual, section by section, to ensure that all concurred resolutions were included, check for spelling, grammar and presentation. After translation, the manual will be uploaded to the website. The manual will be reviewed on an annual basis.

MEETING OF THE WHOLE

Two meetings were held with the Provincial Honours and Awards Chairmen in December 2018 and March 2019. The March meeting focused on Chapter 2 of our manual, Awards. Being a volunteer organization, it was felt that awarding our members for the work that they do is extremely important and could lead to higher retention numbers. However, the number of awards submitted continues to decline. In 2018, 61 applications were received for MSM/MSA and Palm Leaf. On average, 50 Life Membership applications are processed annually. The discussion turned to WHY and HOW to increase these numbers. A number of items were presented for further discussion.

- Are the guidelines too stringent?
- The waiting time between awards too long?
- Paying of per capita for Life Membership difficult for Branches?
- Should the prerequisite of having a Life Membership be dropped for MSM/MSA?

- Should the Life Membership be the ultimate award, after Palm Leaf?

These were the highlights of the ideas presented. Other suggestions were made in conjunction with those listed here.

It was recommend and agreed that the Dominion Committee will research and discuss these ideas and report back to the Committee of the Whole with recommendations to be brought to the next DEC meeting in November 2019.

It was also agreed to fast track re-submissions if there are missing documents such as minutes etc. where otherwise the application would have been approved rather than wait for the next Committee meeting.

D-DAY 75TH ANNIVERSARY PIN

The D-Day 75th Anniversary PIN is now available from our Supply Department. The Ritual, Awards and Protocol Committee recommends that this pin be allowed to be worn on Legion Dress and the uniforms of members of our Ladies Auxiliary on the right lapel below the We Support Our Troops pin until December 31, 2019.

RECOMMENDATION: It was recommended that this pin be allowed to be worn on Legion Dress and the uniforms of members of our Ladies Auxiliary on the right lapel below the We Support Our Troops pin until December 31, 2019.

I ask that a voting member of D.E.C. move this recommendation.

HONOURS & AWARDS APPLICATIONS – NOVEMBER 2018 TO February 2019

AWARD	APPROVED	RETURNED	TOTAL
Palm Leaf - MSM	3	2	5
Palm Leaf - MSA			
MSM	5	3	8
MSA	1		1
Media Award			
Friendship Award			
Total Reviewed	9	5	14

I would ask that a voting member of D.E.C. move this report.

**REPORT OF THE DOMINION COMMAND
CONSTITUTION AND LAWS COMMITTEE
TO THE DOMINION EXECUTIVE COUNCIL
13-14 APRIL 2019**

File: 17-2

J. Rycroft	-	Chairman
D. Eaton	-	Vice-Chairman
B. Chafe	-	Member
G. O'Dair	-	Member
S. Clark	-	Facilitator
L. Taha Cheng	-	Assistant Facilitator

GENERAL

The committee conducted a joint teleconference with Provincial Command C&L Chairs on 21 March. Members continue to review and respond to Constitution and Laws questions by email and telephone as necessary.

PROVINCIAL COMMAND BY-LAW AMENDMENTS

Since the last meeting, the committee reviewed amendments to the By-Laws for SK, ON and NS/NU Commands.

THE GENERAL BY-LAWS MANUAL

The amended By-Law manual was posted online in December 2018 and circulated in that month's All-branch.

I would ask a voting member of DEC to move approval of this report.

**REPORT OF THE DOMINION COMMAND
RCEL COMMITTEE
TO THE DOMINION EXECUTIVE COUNCIL
13-14 APRIL 2019**

**RCL: 26-2-4
26-2-5**

T. Irvine	- Chairman
D. Flannigan	- Vice Chairman
B. Julian	- Member
B. White	- Facilitator
G. Foster	- Assistant Facilitator

COMMITTEE MEETINGS

The RCL RCEL Committee met on 22 November 2018 to discuss the needs of the Commonwealth veterans and widows in the Caribbean as part of our accepted mandate. In all, 16 countries are supported with a total of 51 Veterans and 89 widows being supported in 2019 compared to 57 Veterans and 99 widows in 2018. Donations from branches and individuals continue to be received on a daily/weekly basis at Dominion Command to meet the needs of those in need.

PROBLEM AREAS

Belize

Governance issues continue to plague the Belize Legion with a legal challenge before the courts. At this point the current executive and secretary have been relieved of duties although the secretary continues to act as an administrator. We were however able to get funds delivered and disbursed to those in need in 2018.

Bermuda

Our newest country is still trying to track down all of their Veterans and widows to verify service and eligibility.

EVENTS

This year's bi-annual site visits were conducted between 25-29 January. Veterans and widows were visited at these following islands: St. Lucia; Grenada; St Kitts & Nevis and Dominica (site visit report attached).

FINANCIAL NEWS

The committee continues to use the Libor Grant funding which was distributed to multiple organizations underneath the RCEL umbrella to provide additional grants/assistance to

the veterans and widows of the Caribbean. We will continue to use these funds as mandated until the end of 2019 at which time a detailed report will be submitted to the RCEL HQ breaking down the Libor Grant expenditures. The grants have essentially provided our fund with a three year hiatus from using branch provided donations which have remained strong on an annual basis and has allowed us as we did in 2018 once again to provide supplementary grants such as the Victoria Day and Christmas grants to the Caribbean Veterans and widows (these are issued at 50% of the regular annual grants). This has ensured our fund would be in good standing for the foreseeable future.

CONCLUSION

In closing, as you can see, the numbers of these veterans and widows are dropping rapidly. In some areas where grant support is no longer required, we continue to provide assistance to the local organizations with Poppy materials so that they can conduct annual Poppy campaigns within their countries. It is expected that this will become more prevalent in future years. With the assistance of the branches and Provincial Commands of the RCL, we will continue as mandated to provide support to those in need in the Caribbean.

Comrades, I move acceptance of my report.

2019 RCEL CARIBBEAN SITE VISITS

The Dominion President and the Assistant RCEL Committee Facilitator, conducted site visits to four Caribbean Countries from 25-29 January 2019.

These bi-annual visits allow for an audit of procedures to then be conducted, ensuring that the monies donated are reaching those it is intended for.

Here are the dates and locations visited:

25 January 2019 St Lucia: In St Lucia our contact Earl Francis organized a small wreath laying ceremony at the local cenotaph attended by a local school for children with disabilities followed by visiting three Veterans, five widows and the Governor General his Excellency Emmanuel Neville Cenac.

26 January 2019 Grenada: In Grenada our contact Lauren Grey organized a wreath laying ceremony which was attended by the Governor General Dame Cecile La Grenade and then visits to two Veterans and two widows.

28 January 2019 Dominica: In Dominica our contact Quincy Angol arranged a small wreath laying ceremony followed by visits with three widows and a stop at the local Legion facility.

29 January 2019 St Kitts & Nevis: In St. Kitts we along with our contact John Riley conducted a wreath laying ceremony at the local cenotaph and were fortunate that it was arranged to be attended by the last remaining Veteran on the island, 97 year old Mr. J.P. Williams.

All of these visits were a huge success and it was invaluable to meet face to face with the individual liaisons from each of the Islands. These individuals help disburse our funds and are essentially our "boots on the ground" in these locations and good communications with them is paramount.

All of the Veterans and widows that were visited were extremely appreciative of the assistance that we provide them and each visit was both very heartwarming and enlightening. We have included a slide show of pictures and a small video to help you better see and understand just exactly where your donated funds are going and just how important they truly are.

RCEL 2019 CARIBBEAN SITE VISITS

Remembrance • Tradition • Support • Community • Leadership • Education • Sports

legion.ca

Legion 
There Is Strength And Power In Numbers.

St. Lucia











legion.ca

Legion 

There Is Strength And Power In Numbers.







legion.ca

Legion 
There Is Strength And Power In Numbers.





GRENADA





legion.ca

Legion 
There Is Strength And Power In Numbers.





legion.ca

Legion 
There Is Strength And Power In Numbers.



DOMINICA













D. OF SOCIAL SERVICES,
UNITY DEVELOPMENT
RESIDER AFFAIRS
RATIVE DIVISION
Roval, Roseau, Dominica
Tel: 7547, Fax: 767, 763
E: 767
www.dss.gov.dn

DOMINICA LEGION RCEL

legion.ca

Legion 

There Is Strength And Power In Numbers.

ST. KITTS & NEVIS





legion.ca

Legion 
There Is Strength And Power In Numbers.



In conclusion please watch this video of 96 year old Veteran Mr. Nathan Philip from St. Lucia who insisted on singing us a song before we left!

legion.ca

Legion 
There Is Strength And Power In Numbers.

**REPORT OF THE DOMINION COMMAND
DOMINION CONVENTION COMMITTEE
TO THE DOMINION EXECUTIVE COUNCIL
13-14 APRIL 2019**

File: 19-1

T. Irvine	-	Chair
B. Julian	-	Member
B. Chafe	-	Member
B. White	-	Facilitator
S. Clark	-	Assistant Facilitator
D. Martin	-	Assistant Facilitator

48TH DOMINION CONVENTION, SASKATOON, SK, 22-27 AUGUST 2020

Planning for this convention continues; the second meeting with the Saskatoon Local Arrangements Committee is tentatively scheduled for 21 September 2019. The LAC co-Chairs, Comrades Pat Varga and Brent Wignes, are supported by an excellent committee.

CONVENTION FACILITIES

Two facilities will be used: TCU Place will host the Registration and Exhibit Area, Opening and Closing Ceremonies, Business Sessions and all caucus meetings; the Welcome Reception and the pre- and post- DEC and SEO meetings will be held at the Delta Bessborough.

ACCOMMODATIONS

The Command Hotel is the Delta Bessborough, a 10-minute walk from TCU Place. Other hotels contracted include the Best Western Royal, Best Western Plus Blairmore, Best Western Plus East Side, The James, Sheraton Cavalier, Parktown, Ramada, Radisson, Hilton Garden Inn and Holiday Inn. Nightly rates range from \$154-\$289.

CONVENTION CALL

The Convention Call will be issued in December 2019.

REGISTRATION FEES

The registration fee for delegates (\$60) and observers (\$20) was increased to those rates for the 2016 Dominion Convention. The following recommendation is brought forward for DEC consideration and approval:

RECOMMENDATION: It is recommended that the convention registration fee for delegates and observers remain unchanged for the 2020 Dominion Convention.

EXHIBITORS

The fee charged for a booth in the exhibit area was increased for the 2016 Dominion Convention to \$800 for companies and \$450 for individuals. The following recommendation is brought forward for DEC consideration and approval:

RECOMMENDATION: It is recommended that the convention exhibitor fees remain unchanged for the 2020 Dominion Convention.

LOGO AND THEME

The convention logo and theme will be discussed with the LAC in September and reported at a future DEC meeting.

KEYNOTE SPEAKERS AND PRESENTATIONS

Speakers and presentations at the 2018 Dominion Convention included:

- 3 Keynote Speakers: Minister VAC, RCMP, CAF
- 1 Speaker, Other: National Silver Cross Mother
- 2 Greetings, International: RBL, American Legion
- 2 Greetings, Other: Veterans Ombudsman, Cadet Leagues
- 3 Presentations, Legion: RCEL, Founders Award, Pilgrimage
- 2 Presentations, Other: Nijmegen March, Outlaw Motorcycle Groups

For the 2020 Convention, it is intended to continue to schedule three Keynote speakers and greetings from international, fraternal organizations. Greetings and presentations by non-Legion groups and individuals will be kept to a minimum. As noted in November, there will be no speakers or greetings delivered on Wednesday, the final day of convention, to allow the focus to be on brought-back resolutions.

WORKSHOPS

The pre-convention workshops continue to be popular. Four workshops will again be offered in 2020; topics remain to be determined.

FUTURE CONVENTION ACTIVITIES

The following is a list of activities regarding future conventions:

- a. 2022 Convention, Saint John, NB, 20-25 August 2022: No new developments

- b. 2024 Convention, Ontario, 24-29 August 2024: Liaison with ON Command continues to identify a location.
- c. 2026 Convention, Winnipeg, MB, 22-27 August 2026: Contracts with hotels and the convention centre have not been initiated.
- d. 2028 Convention, British Columbia: A location has not yet been identified.

I move the acceptance of my report.

**REPORT OF THE DOMINION COMMAND
DEFENCE AND SECURITY COMMITTEE
TO THE DOMINION EXECUTIVE COUNCIL
13-14 APRIL 2019**

File: 82-27

R. Blanchette	-	Chairman
R. Price	-	Vice Chairman
W. Martin	-	Member
B. Cl��roux	-	Member
J. Milne		Member
C. Gasser	-	Facilitator
M. Smith	-	Assistant Facilitator

GENERAL

This report covers the period from the last DEC on 25 November 2018 to 13 April 2019.

The Committee continues to monitor defence and security issues as they arise and has met on 29 March 2019.

COMMITTEE BUSINESS

The Committee has welcomed a new member, Comrade Jay Milne, who retired last year from the Canadian Armed Forces at the rank of Major-General after 37 years of service, including 24 years in the reserve. In his last position, he was accountable to the Deputy Minister of Veterans Affairs and to the Chief of the Defence Staff as strategic liaison officer on key issues crossing the two departments.

D&S Command Representatives Network. As explained in previous reports, the D&S CR network will provide the mechanism by which a D&S advocacy platform will be developed from Commands' suggestions and feedback. To facilitate its preparation, the Committee will network with the Conference of Defence Associations (the RCL is a member of CDA). A draft letter of understanding (LoU) has been presented to CDA and its authorities have enthusiastically supported the initiative as it fits well with its "OP RENEW" project.

CDA Annual General Meeting. The Chair attended the AGM on 11 Feb 2019. As the member of CDA with by far the largest constituency, the RCL is an important player in how the organization wants to review its operating model (OP RENEW). Accordingly, the CDA chair, VAdm (ret) Denis Rouleau expressed his satisfaction in seeing the kind of cooperation the RCL is developing with CDA and the CDA Institute. He also announced that BGen (ret) Matthew Overton will be replaced by Dr. Yuri Cormier in the post of Executive Director of CDA and the CDA Institute.

Ottawa Security Conference. Members of the Committee attended this conference on 12 and 13 February 2019. It constitutes the main D&S event of the Ottawa scene and it was well attended even if the second day was hampered by a major snow storm. Main speakers were Steven MacKinnon (MP Gatineau and Parliamentary Secretary to the Minister of Public Services and Procurement and Accessibility), LGen Paul Wynnyk (VCDS) and Gen Terrence O'Shaughnessy (Commander NORAD).

Office calls to the leadership of the CAF and the RCMP. The Chair and the RCMP member of the Committee will meet with Commissioner Brenda Lucki on 12 April 2019. Further information will be verbally provided at the DEC. Other office calls are being planned with the new commanders of RCN, CA and RCAF.

2019 NIJMEGEN MARCH

The RCL candidate and alternate will be selected at the time of the Committee meeting on the 29th March 2019 and announce verbally at DEC. Twelve applications in total were received from six Provincial Commands.

2019 OP CANADA DAY

The RCL will be sending 2770 packages to CAF and RCMP members deployed across the world this Canada Day.

COMMITTEE COORDINATION

The Committee continues to maintain a presence (through the Chair and Secretary) at the Veteran's Consultation Assembly and the VSS Committee (through the Director of Veterans Services and the Secretary who is the Deputy Director of Veterans Services) to ensure coordinated understanding and efforts.

CONCLUSION

In the absence of questions or discussions, I would ask a voting member of DEC to move acceptance of this report.

**ADDENDUM TO THE
REPORT OF THE DOMINION COMMAND
DEFENCE AND SECURITY COMMITTEE TO
THE DOMINION EXECUTIVE COUNCIL**

13 April 2019

File 82-27

Richard Blanchette	-	Chairman
Randy Price	-	Vice Chairman
Wayne Martin	-	Member (via telecom)
Bob Cl��roux	-	Member
Jay Milne	-	Member
Carolyn Gasser	-	Secretary
Mike Smith	-	A/Secretary

GENERAL

The D&S Committee met on 29 March 2019.

DRAFT LOU WITH CDA/CDAI

The Chair attended the Conference of Defence Associations (CDA) AGM on 11 February 2019. At that meeting, the CDA chair and the Executive Director reiterated their interest in cooperating with the Legion for the development of an advocacy platform from the feedback that will eventually be received from the D&S Command Representatives (CR) network. The Chair of the D&S committee informally presented the latest version of the letter of understanding (LoU) to VAdm (ret) Rouleau (CDA Chairman) to continue the consultation process between the two organizations.

Further to the Committee's decision to ask the C&L Committee to review the draft LoU, the following motion is presented to the DEC:

MOTION: That the latest version of the LoU (Version 5 dated 29 March 2019 – attached), once reviewed by the Constitution and Laws (C&L) Committee, be circulated to obtain signatures from the six signatories who are, for the RCL, the Dominion President, the Chair of the D&S Committee and the Dominion Secretary, and for the CDA and the CDA Institute, VAdm (ret) Rouleau, MGen (ret) Gosselin and the new Executive Director of both organizations, Dr. Youri Cormier.

NIJMEGEN APPLICATIONS AND SELECTION PROCESS

The Committee was very impressed with the quality of applications for Nijmegen 2019. Members individually reviewed the applications prior to the meeting and discussed various aspects. As both first and alternate candidates were able to participate in 2018, it was decided that three candidates would be selected this year while awaiting a CAF confirmation of the number of Legion representatives allowed to participate.

The three top candidates are respectively Comrade Colin Robinson from Quebec, Comrade Douglas Cody from Ontario, and Comrade Derk Grooten from BC/Yukon.

The Secretary will advise the CAF of this selection and provide their contact information. If #3 or #2 are not participating in the 2019 Nijmegen March, they will be given an advantage if they reapply for 2020, should they still be deemed fit and willing to participate.

RESIGNATIONS OF COMMITTEE CO-CHAIR AND CHAIR

Comrade Randy Price, who was the Committee Co-Chair, attended his last Committee meeting on 29 March 2019 after serving with great dedication for more than 10 years on the Committee.

Comrade Richard Blanchette submitted his resignation as Chair of the D&S Committee to the Dominion President on 4 April 2019 and it was accepted on 9 April 2019. He served in this role since the Fall of 2014. He will not attend DEC and he takes this opportunity to send his regards to all of his RCL colleagues.

**REPORT OF THE DOMINION COMMAND
VETERANS CONSULTATION ASSEMBLY
TO THE DOMINION EXECUTIVE COUNCIL
13-14 APRIL 2019**

L. Murray - Chairman
T. Irvine - Member
B. Julian - Member
R. Blanchette - Member
B. White - Facilitator
R. McInnis - Assistant Facilitator

GENERAL

There has been no Committee activity since the last report to DEC in November 2018. The Minister of VAC acknowledged receipt of the two letters sent on behalf of the Committee as a result of the last meeting.

No formal replay has been received.

I would ask a member of DEC to move approval of this report.

**REPORT OF THE DOMINION COMMAND
GOING FORWARD COMMITTEE
TO THE DOMINION EXECUTIVE COUNCIL
13-14 APRIL 2019**

File: 10-1-1

B. Julian	-	Chairman
T. Irvine	-	Vice Chairman
C. Richardson	-	Member
L. Murray	-	Member
K. Scott	-	Member
R. Zettler	-	Member
B. White	-	Facilitator
S. Clark	-	Asst Facilitator

INTRODUCTION

The Going Forward Committee met by teleconference on 6 February 2019.

TERMS OF REFERENCE

The Committee reviewed and approved a draft set of revised Terms of Reference. (Attached)

RECOMMENDATION: The Committee recommends that DEC approve the Terms of Reference for the Going Forward Committee.

STRATEGIC PLAN.

The Committee reviewed the six strategic objectives.

In consideration of the plan, the committee will provide support and advice to other committees as the objectives are mostly within the Dominion Committees mandates. Specifically, for the Going Forward Committee, the areas of Governance, Infrastructure and Modernization, and Membership as the primary areas of focus.

Further discussions will be necessary to determine how best to approach these areas and define what resources are needed. However, it will be essential to engage other committees and elected officers of the Legion.

STOLEN VALOUR

Although Stolen Valour is not a new phenomenon, social media is very active with Stolen Valour Canada (SVC) actively pursuing individuals who falsely wear uniforms and medals to promote themselves as something they are not. The Dominion President is very keen

to ensure that positive actions against those Legionnaires who are committing Stolen Valour happens. BC/Yukon Command is actively developing a provincial policy and, with their consent, that same policy was revised to reflect a national policy.

RECOMMENDATION: The Committee recommends that DEC approve the national Stolen Valour policy as follows:

“Branches may become aware of suspected cases of Stolen Valour through a number of possible ways:

- From members,
- From Legion Levels of Authority who would in turn have found out through a member complaint or from SVC,
- On line, through social media, report from the public, or the SVC website.

In any of these cases, it is important to respect our members’ right to due process and to have their side heard. At the same time, fraudulent wearing of medals or uniforms is a federal crime, and branch executives are responsible to protect their branch’s reputation and the reputation of the Royal Canadian Legion.

When made aware of suspected Stolen Valour, branch Presidents are to:

- Identify someone who can speak to the person accused of Stolen Valour. That individual can be the President themselves, or a trusted member of the branch who the person accused is comfortable talking to,
- Explain the accusation to the person, and explain the potential impact on the branch and the Legion if it were to be true.
- Give the person the opportunity to tell their side of the story. Ideally, the conversation will either clear up the situation by providing the President evidence that there is no case, or it will allow the person accused the opportunity to understand the potential harm they could cause and give them an opportunity to redeem themselves by surrendering those items that they were wearing fraudulently.
- Report to their Command headquarters through the appropriate channels how the issue has been resolved.

If the individual in question refuses to surrender the decorations or medals and cannot provide a reasonable explanation as to their validity, a branch president has some options:

- They can notify law enforcement authorities of an alleged breach of Criminal Code S. 419,
- If any member believes that the alleged Stolen Valour constitutes conduct that brings or tends to bring the Legion into discredit, a complaint can be lodged under Article III of the General By-Laws. As per General By-Law 304H, a branch president may deprive the member against whom the complaint is lodged of clubhouse privileges and remove them from office or position.

It is not recommended that the branch President officially engage with or solicit assistance from SVC; they are not an arm or resource of the Royal Canadian Legion and should not be treated as such. However, the member accused of Stolen Valour are to be made aware that SVC rarely lets an allegation go if they believe they have a case.

The Committee would like to thank BC/Yukon Command for consenting to the use of the policy nationally.

FINANCIAL FUTURE

The financial future of the Legion has been an ongoing topic as our membership numbers, which derive our principle form of funding, declines.

While the focus on building a strong membership continues as a strategic objective for 2026, the Committee agrees that new streams of revenue need to be found to augment membership dues. Ideas of what those potential streams are will be solicited. As well as canvassing for best practices from branches across the Legion. The eventual outcome will be a resource package that will be available to all so that best practices become the norm in all branches.

BRANCHES IN UNIVERSITIES

Comrade Richardson brought up the idea of encouraging the formation of branches in universities to enhance comradeship and community support. The idea is with merit and if branches were formed, they would not necessarily be along the same concept of branches as we know them today.

The Chair, as the Chair of the Membership Committee, will take this concept to the Membership Committee for consideration.

I move the acceptance of this Report.

GOING FORWARD COMMITTEE TERMS OF REFERENCE

File: 10-1-1

BACKGROUND

For the past decade the Legion has been examining its operations with a view to continuing well into the future. In July 2026, the Legion will celebrate its centenary with the full intention of fulfilling its mandate and mission of supporting Veterans and their families, preserving Remembrance and supporting Canada's communities.

In 2018, the Legion approved at Dominion Convention, a Strategic Plan. This plan has been long in development by initially the Focus on the Future Committee and now the Going Forward Committee. It is a long term view of commencing a change within the Legion so that sustainment of programs and services can be achieved.

A sustainable and vibrant Legion is as critical now as it was when the various organizations came together in 1926 to form the Legion. Canada's Veterans need and deserve it.

AIM

The aim of the Committee is guide and review the implementation of the Legion's Strategic Plan and to report on its effectiveness.

COMMITTEE COMPOSITION

The Dominion President will decide on the composition of the Committee which as a minimum will have a Chairman, Vice Chairman and four members. The National Executive Director and Director of Corporate Services will serve as Committee administrators with support from the Executive Director's Executive Assistant.

OUTCOMES

The Strategic Plan has identified six objectives:

- Expand membership to 300,000 by 2026
- Improve communications and public awareness
- Forster a welcoming culture across the Legion
- Increase recognition and value
- Modernize infrastructure
- Improve governance effectiveness and performance measurement

The Dominion President has provided committee mandates and the Going Forward Committee will be focused on:

- Improving governance effectiveness and performance measurement
- Assessing measures designed to modernize infrastructure
- Coordinating and assisting other committees in achieving the objectives assigned to them
- Other issues that may be assigned to the Committee by the Dominion President

REPORTING

The Committee will report to the Dominion Executive Council or the Dominion Convention when those bodies are in session. The Committee will actively engage with other committees to assist whenever and wherever needed.

January 2019

ITEM 9: CANVET PUBLICATIONS LTD.

B. Julian	-	Board Chairman
T. Irvine	-	Board Vice-Chairman
D. Flannigan	-	Secretary
T. Bursey	-	Director
B. Chafe	-	Director
O. Parkhouse	-	Director
A. Stanfield	-	Director
L. Tardif	-	Director
B. Weaver	-	Director
I. Weiser	-	Director

INTRODUCTION

Canvet works hard to create a better understanding of Canada's military history and our veterans' achievements at home and around the world. *Legion Magazine* is the country's third-largest and third-oldest periodical. The news from Canvet is positive and the magazine is healthy and thriving. If the magazine remains eligible for the Canada Periodical Fund (CPF) then Canvet can extend its commitment to continue operations under the existing subscription fee until 2022. This is a two-year extension.

SUBSIDY REVENUE

In late 2018, Canvet applied for the CPF and are typically informed by summer whether the application is successful and if so the amount of funding. Canvet's budgets are predicated on the receipt of this subsidy and the corporation is optimistic.

Last year, the CPF awarded the magazine the highest subsidy in its history--\$904,210. This was a five per cent (\$42,632) increase over the previous grant of \$861,578.

To put this in context, the magazine has received almost 12 million dollars in the last 30 years and the annual grant amount has tripled in size. The CPF is essential for the magazine's survival and requires strict adherence to the rules. The government must be confident that *Legion Magazine* is an independent operation. They have listed as ineligible any periodicals "that primarily report on the activities or promotes the interests of the organization."

Canvet also received \$75,000 in funding from the Ontario Media Development Corporation (OMDC) which is allocated over three years, ending in 2019.

WWW.LEGIONMAGAZINE.COM AND SOCIAL MEDIA

The Military Moments, tributes and remembrance videos have generated almost 2.8 million views (1.6 million on Facebook and 1.2 million on YouTube) and are available for the Legion to use to promote remembrance and Canadian military history. In 2018, legionmagazine.com attracted 1.4 million visitors. The site showcases our award-winning interactive websites, videos, blogs, historic photo archives, audios and the Last Post database with almost 200,000 names.

EDITORIAL

After extensive coverage of the 75th anniversary of D-Day, the magazine will turn to coverage of the 75th anniversary of the Battle of the Scheldt, the RCL Pilgrimage of Remembrance, provincial commands, cribbage, darts, eight ball and track and field.

MEMBER BENEFITS PACKAGE

The Royal Canadian Legion (RCL) Member Benefits Package (MBP) offers discounts on specialty designed travel insurance packages, retirement living, cell phones, eyewear, funerals and much more. The partners include HearingLife Canada, Carlson Wagonlit Travel, IRIS Eyewear, Medipac Travel Insurance, Revera Inc., Arbor Memorial Services Inc., HomeEquity Bank, Canadian Safe Step Walk-in Tub Co., SimplyConnect and MBNA Canada Inc.

Each of the ten partners contributes to the Legion and its members in a different way. Some provide funding to Dominion Command programs while others continue to offer their discounts to both the member and their immediate family. Canvet offers the partners exclusive rates to advertise and the partners reach an exclusive market as an endorsed partner.

AWARDS & RECOGNITION

Late last year, Canvet was awarded gold from Canadian Online Publishing Awards for the interactive/infographic site on Prisoners of War and was also named a finalist for our video on the Somme narrated by Linden MacIntyre.

Legion Magazine has also been publishing a series of portraits on veterans who have sustained physical and psychological wounds from their service. The Canadian War Museum has partnered with Canvet to create a national exhibition, *The Wounded*, which features 18 large-format black-and-white photographs of Canadian veterans, primarily from the Afghanistan war. Staff writer Stephen Thorne took black and white photographs of veterans from across the country and the results were remarkable. The exhibition is on display at the museum until June. The museum intends to extend this as an international travelling exhibition.

OPERATION SANTA CLAUS

For over twenty years Canvet has been donating magazines to Canadian Forces (CF) personnel on peacekeeping assignments and in isolated posts around the world. In 2018, we provided 3,000 magazines which represents a donation of \$17,850.

CONCLUSION

This report is for information only.

**REPORT OF THE
LEGION NATIONAL FOUNDATION
TO THE DOMINION EXECUTIVE COUNCIL
13-14 APRIL 2019**

File: 10-18

BOARD OF DIRECTORS

D. Flannigan	-	Chair
G. O'Dair	-	Vice-Chair
B. Burnham	-	Director
L. Murray	-	Director
P. Kavanagh	-	Director
B. White	-	Executive Director
S. Laprade	-	Director of Development
S. Clark	-	Secretary

GENERAL

This report is provided for the information of the Dominion Executive Council. The Foundation's Board of Directors last met by on 12 January 2019.

CASE FOR SUPPORT

Members determined the need for a defined approach on supporting specific programs using a varied communication format depending on the target market. The pillars of Veterans Care (mental health, research, homelessness) and Education (cadets/other youth groups, battlefield tours, pilgrimages, scholarships and bursaries, Remembrance) were explored. The Foundation liaised with the Poppy and Remembrance Committee on the changes to the recommendations proposed for the former Legion programs.

DIRECTOR OF DEVELOPMENT

To progress the work of the LNF, the Board approved the hiring of a Director of Development to provide professional fundraising leadership and to develop and execute a strategic fundraising plan to include approaches to individuals, corporations and other foundations. The LNF is pleased to announce that Ms. Sam Laprade, CFRE, has accepted to join the LNF in this role. Ms. Laprade's experience includes legacy giving, capital campaigns, direct mail and special events. A major gifts officer in Ottawa, she worked previously for the Ottawa Humane Society, The Ottawa Hospital Foundation and the Ottawa Mission.

The first areas of focus for Ms. Laprade is drafting LNF policies and procedures, undertaking board and donor relations, applying for grants and establishing a case for support and a fundraising plan for 2019 / 2020.

GIFT ACCEPTANCE POLICY

A gift acceptance policy has been drafted to ensure all donations accepted by the Legion National Foundation adhere to the mandate and values of the organization. This policy, to be approved by the Foundation Board, clearly outlines the types of gifts that will be accepted to advance the organization's objectives, for example property. Other areas addressed in the policy include ethics, donor rights and recognition, as well as, confidentiality.

This report is provided for the information of the Dominion Executive Council.

ITEM 11: NATIONAL EXECUTIVE DIRECTOR'S REPORT

Comrades, as this is my last report to DEC, I would like to take this time to thank all of you and those who have been in your seats before you, for the time and effort, as well as devotion, to this great organization. My 20 + years have been interesting to say the least but very much rewarding professionally and personally.

The Legion has a great future if we all work collectively to pursue our Purposes and Objects. It pays to review them occasionally to ensure that we are grounded in our aims. That is not to say that we need to avoid change, as change is necessary and essential for the Legion to move into the future and to continue to provide the essential services to both our Veterans and our Communities.

Thank you for allowing me to part of this great organization. I never imagined the Legion to become my second home outside of the military. Therese and I have made many great friends and shared so many different experiences. We thank you for that.

Never forget that we are a benevolence provider to our Veterans and Communities. That is what we do best and that is what we must continue to do.

To conclude, I want to acknowledge publically my team. They are great and some of the best that I have ever had the privilege of leading. No, they are not all warriors, but they do not need to be. They are all essential people to the functioning of the National Headquarters and they all bring a service attitude each and every day to their jobs. I especially also want to recognize my Chief Financial Officer, Comrade Tim Murphy, who is preceding my retirement by a week. Tim has provided the Legion with sound and accurate financial advice for the past 16 years and to me as Executive Director for the past 10 years. Thank you Tim for your sage advice and best wishes for a fun retirement.

Supply Items

i. Sales as of the end of February 2019 are as follows:

	2016	2017	2018	2019
JANUARY	120,582	184,616	120,235	146,471
FEBRUARY	96,950	151,078	98,575	114,287
YTD			218,810	260,759 (+19%)
MARCH	172,388	266,990	137,210	
APRIL	159,673	256,830	195,655	
MAY	146,955	264,469	200,697	

JUNE	*201,036	212,030	148,375	
JULY	103,017	112,671	86,316	
AUGUST	158,243	166,165	199,301	
SEPTEMBER	244,238	177,688	*218,934	
OCTOBER	361,941	399,511	479,512	
NOVEMBER	419,941	362,495	366,381	
DECEMBER	108,165	138,736	110,992	
TOTAL	2,293,129 (-7%)	2,693,279 (+17%)	2,362,183 (-12%)	

* Includes June 2016 Convention Sales of \$59,993

* Includes August 2018 Convention Sales of \$40,011

The first few months of 2019 are producing good results and sales were strong in the last 5 months of 2018. Armistice 100 products did well selling completely out of stock. Sales from our online www.poppystore.ca and wholesales have increased in volume. In 2018, the online store handled 8,621 online orders generating \$508,583, an increase of **(+26%)** in sales from 2017. Wholesale orders in 2018 generated \$186,030 in sales. Sales from these channels continue to grow our overall revenue.

ii. Second quarter sales are expected to remain strong with the release in late March/early April of the D-Day 75th Anniversary commemorative pin, ball cap and t-shirt.

iii. A number of new products are in the development and production stage for release in 2019. A new line of clothing including ball caps, jacket, golf shirts, sun hat and some new clothing items designed for women only. In addition, we are looking at revamping commemorative items for Afghanistan. This fall will also bring a new round of product still in the design stage, such as, hoodies, a playing card case, and portfolio just to name a few.

iv. Sales of Legion Lager continue to accelerate. In 2018, we had distribution in BC and the launch at the Dominion Convention for distribution in Manitoba. In 2019, we will start with the launch of Legion Lager in Saskatchewan in the March-April period. The product is offered in many Brewers Retail locations, Legion branches, restaurants, grocery stores and it is now being offer at the Ontario LCBO. Draft is also available. To date the Provinces with distribution are Ontario, BC, Manitoba and Saskatchewan. Whitewater's goal is to have Legion Lager in all Provinces by the summer of 2019.

v. Supporting committee activities continues to be a major focus for supply and includes promotional materials for the Poppy Campaign, the production of Poppies and Wreaths, Track and Field and Legion Sport materials, and gifts for the Defence & Security Committee's support to Operation Santa Claus and Canada Day.

vi. Since November, supply has been dealing with a trademark concern from DND regarding shirts and hats that are similar in design to the CAF's CADPAT design. While

the design is different, DND believes we have violated "Crown Intellectual property". As a good faith gesture, we offered to stop selling the products once stock was depleted. This wasn't sufficient for DND which asked us donate all profits of the product to the Support our Troops charity. The Legion already supports several Canadian Forces Morale and Welfare services lead programs including the Army Run, Navy Bike ride as well as operation Santa Claus and Canada Day so we do not feel this is a fair ask. We've subsequently have had our lawyer reach out for clarity on exactly how we've violated "crown intellectual property" so we can better address their concerns. As of today, we are awaiting a response from DND. Our lawyer feels we have a very strong defense in this matter. More information will be shared once we have a resolution in this matter.

Member Services

You are all aware of the progress that has been made in the processing of memberships and its modernization. Surprisingly, we still have branches out there encouraging their members to not use the membership portal to renew. Again, there are some that prefer to go to the branch to renew, but there are others that would prefer to renew on line. We must cater to both if we want to continue to retain our members.

Gross Margin

The revised gross margin calculations were distributed and is attached to this report. As I stated in the email, I was a little hasty in sending out the initial numbers before Tim had an opportunity to check them all. Mia culpa.

Provincial Executive Director Seminar

Following last Fall's DEC meeting, the Provincial Executive Directors remained at the National Headquarters for a seminar. Each province had a representative and the subjects covered were: Command structure and functions at Legion House, Constitution and Laws, Poppy Regulations and funds, Canvet, Veterans Services, Membership, Programming and Conventions, Marketing and Communications, and Public Relations. The final session was a roundtable where general discussion ensued.

All found the seminar to be very educational as well as promoting cooperation and understanding. The Public Relations session was extremely beneficial even for the those who have shied away from public speaking and the media.

I strongly suggest that DEC consider continuing this practice. At each Dominion Convention, the Executive Directors meet. In the off-years a seminar hosted at Dominion Command would prove equally beneficially and this should be considered in the budget planning process.

Marketing

2019 marks the start of the third year of the five-year marketing plan, presented to and approved by DEC in November 2016.

Marketing and communications continue to work diligently to ensure the Royal Canadian Legion is in the hearts and minds of millions of Canadians across this country. To date, the full budget allocation for 2017 and 2018 was leveraged, and each of the marketing strategies outlined in the plan have been executed. Here are just a few highlights:

- a. National TV and Radio spots – multiple National broadcasters are airing the Legion’s TV and radio public service announcements. Many stations have aired the PSA’s in Q1 nationally. This equates to tens of millions of dollars in free advertising for the Legion over the course of the year. Updated versions of both radio and TV spots are currently underway with deployment scheduled for fall 2019.
- b. Content on Legion.ca is seeing increased traffic to targeted pages, with more than 1.7 million page views received (up 10% over 2017; over 650K new visitors to in 2018 (up 22% over 2017), achieved through organic search, direct search and social media . We are currently updating the content management system to the latest version of Sitefinity, which will make it easier and faster to update the content.
- c. Social media posts promoting all aspects of Legion activity and programs are seen by hundreds of thousands monthly, and we have seen significant growth in positive, supportive commentary from those who engage on our social media platforms.
- d. Other marketing elements such as email, direct mail, online banners, and print ads are increasing the exposure of the Legion and seen by hundreds of thousands of Canadians. We launched multiple online campaigns in January (with a join the Legion message), placed a renewal ad in Legion mag in Jan and March issues and dropped our annual Renewal mailer to over 60,000 in March. Email was sent in January to 60K Veterans on CFMWS email list to encourage them to apply for the Veteran Welcome Program (free 1 year membership)
- e. Communications to our members has increased with our ongoing member newsletters, and our monthly all-branch newsletters, keeping members up to date and appraised of Legion activities, initiatives, and advocacy efforts. Several email reminders were sent in January and February to remind members to renew, all branch emails are sent each month and the first member enewsletter was sent in February. Five more newsletters are planned for remainder of the year.
- f. Significant awareness for the Legion also came from our participation in the Amazing Race Canada program on CTV this past summer.

This plan to date has met our expectations to reduce the decline and see growth in new acquisitions. It was understood from the start that when the plan was developed, it came with caveats that other improvements would be required in order for us to be successful. These included:

- a. Adopting a more inclusive organization culture
 - i. From a marketing perspective, work on improving organizational culture continues with the establishment of the Legion's Strategic Plan and implementation of the hospitality plan. Changing culture will be a process, no doubt, and our message of change needs repeating at every opportunity we present to Branches and Commands. Next up will be the provincial conventions where this will be a strong theme in the Dominion President's address by the visiting SEO.
- b. Implementation of the membership portal
 - i. A long awaited and very important member acquisition and renewal system was implemented last year – a step necessary to make joining and renewing easy and convenient for our members. Launched in July of 2017, there are currently over 29K members registered, and 85% of branches that have entered their membership rates into the system. It is vital for branches to come on board, allowing us to simplify the process of renewals for our members. We have sent multiple reminders in Q1 via email including providing incentives to branches to enter the rate.
- c. Adopting a rolling anniversary based membership model vs calendar year model
 - i. Moving to a rolling anniversary membership model where the month you join is the month you renew each year will significantly improve our ability to sign up new members later in the year as well as ease the burden on membership processing, allowing for a smoother and timelier renewal process. To date, this has not been implemented, but it is something that should be reviewed and discussed as it will only further our ability to generate membership growth.
- d. Strong communication strategy
 - i. A 5-year communications strategy has been developed and approved and our Communications Manager works daily to execute the strategy and generate positive earned media to compliment the marketing efforts. We still require the support of the SEO's and Provincial Commands to ensure the message remains positive. The annual Public Relations workshop at DEC supports this aim. Provincial Executive Directors received training in November as well to further its impact. It is vital that we are all on the same page with both our external and internal communications; otherwise divided, we will not focus on our mission.

As you can see, we are at various stages with the improvements that are needed in order to be truly successful in achieving membership growth. While the 5-year marketing plan positions the organization to promote the great work we do and the benefits of membership, these overlying concerns impact marketing and communication's ability to fully achieve objectives for membership growth. It is crucial these are addressed.

As we continue on it 2019 with a solid plan, a committed team, and evidence of success thus far, we are confident in building on our accomplishments and seeing us achieve membership growth in the near term, something not done in over 30 years.

CONCLUSION

Comrades, that concludes my report. Are there any questions?

Sales Total By Command for the Year 2018

ANNEX "1" TO
DEC MINUTES
13-14 APRIL 2019

	COMMAND	BRANCH	LA BRANCH	DISTRICT	ZONE	MEMBER	MISC.	TOTAL	TOTAL PC SALES	% BY COMMAND	GROSS MARGIN SHARE	LEGION LAGER			
B.C. /YUKON	\$4,760.30	\$130,735.73	\$7,432.47	\$0.00	\$141.06	\$13,907.36	\$0.00	\$156,976.92		10.12%	\$6,655.61	\$156,976.92	10.12%	\$115.80	\$6,771.41
ALBERTA-NWT	\$1,085.58	\$165,235.76	\$3,589.20	\$370.71	\$0.00	\$19,669.80	\$0.00	\$189,951.05		12.24%	\$8,053.67	\$189,951.05	12.24%	\$140.12	\$8,193.80
SASK.	\$2,709.22	\$60,216.79	\$75.00	\$0.00	\$576.51	\$6,747.89	\$0.00	\$70,325.41		4.53%	\$2,981.70	\$70,325.41	4.53%	\$51.88	\$3,033.58
MAN. & N/W ONT.	\$1,128.82	\$84,382.84	\$3,162.09	-\$31.88	\$513.15	\$7,126.67	\$0.00	\$96,281.69		6.21%	\$4,082.22	\$96,281.69	6.21%	\$71.03	\$4,153.24
ONT.	\$6,638.98	\$556,709.49	\$30,344.64	\$1,369.74	\$9,159.11	\$57,745.18	\$0.00	\$661,967.14		42.67%	\$28,066.53	\$661,967.14	42.67%	\$488.32	\$28,554.86
QUEBEC	\$6,498.45	\$95,351.24	\$231.08	\$911.33	\$0.00	\$9,098.75	\$0.00	\$112,090.85		7.22%	\$4,752.50	\$112,090.85	7.22%	\$82.69	\$4,835.19
N.B.	\$2,657.57	\$55,567.39	\$2,967.29	\$313.00	\$0.00	\$5,965.25	\$0.00	\$67,470.50		4.35%	\$2,860.66	\$67,470.50	4.35%	\$49.77	\$2,910.43
NOVA SCOTIA/NUNAVUT	\$2,338.36	\$114,033.30	\$1,085.27	\$50.00	\$69.95	\$8,340.01	\$0.00	\$125,916.89		8.12%	\$5,338.71	\$125,916.89	8.12%	\$92.89	\$5,431.60
P.E.I.	\$279.55	\$11,350.95	\$390.00	\$0.00	\$0.00	\$1,248.85	\$0.00	\$13,269.35		0.86%	\$562.60	\$13,269.35	0.86%	\$9.79	\$572.39
NFLD. & LAB	\$2,663.89	\$52,094.57	\$0.00	\$20.00	\$0.00	\$2,409.21	\$0.00	\$57,187.67		3.69%	\$2,424.68	\$57,187.67	3.69%	\$42.19	\$2,466.87
US	\$0.00	\$2,349.24	\$0.00	\$0.00	\$0.00	\$244.50	\$0.00	\$2,593.74					100.00%	\$1,144.48	\$66,923.38
EUROPE	\$0.00	\$1,240.37	\$0.00	\$0.00	\$0.00	\$176.75	\$0.00	\$1,417.12							
MISC	\$0.00	\$0.00	\$0.00	\$0.00	\$0.00	\$0.00	\$806,734.75	\$806,734.75							
								\$2,362,183.08	\$1,551,437.47	100.00%	\$65,778.90	\$1,551,437.47			
5% GROSS MARGIN (including Legion Lager)			\$66,923.40												
								SALES OF SUPPLIES	2,362,183.00			LEGION LAGER ROYALTY	22,889.50		
								COST OF GOODS SOLD	1,046,605.00						
	Supply Sales		65,778.90												
	Legion Lager Royalty		1,144.48					GROSS MARGIN ON SUPPLY SALES	1,315,578.00						
			66,923.38					DISTRIBUTION TO PROV CMD @ 5%	65,778.90			@ 5%	1,144.48		
			0.02												
Miscellaneous include sales directly to non-Legion entities such as the government, museums, wholesales, DND, cadet groups, consumers, business, US and Europe Zones, and staff.															

It's Our Duty: The Royal Canadian Legion advocacy agenda 2019

FOUNDATIONAL ITEMS

Action is required to improve overall quality of life.

- ***Homelessness*** - we want to see a comprehensive national veterans' homelessness strategy in Canada, with a specific focus on getting veterans off the streets. This strategy should identify gaps in knowledge and service delivery and be coordinated with other service providers.
- ***VIP and Long Term Care access*** - we would like to see increased access to Veterans Independence Program benefits for frail veterans, allowing them to stay in their homes longer. We would also like VAC to enact legislation so that at the time of a veteran's death, the VIP benefits are accessible to a Survivor whenever needed. In addition, we want all eligible Canadian Armed Forces veterans to receive preferred access to vacant Long Term Care beds.
- ***Transition*** – we would like to see more attention paid to how we transition veterans back into civilian life. We need tangible evidence that as promised by our government, military members who are seriously disabled due to service are not being medically released until they are in stable condition, their medical records transferred to VAC, and a case manager assigned.
- ***Veterans and the Census*** – we support the inclusion of a new question in the next short form census in 2021, in an effort to identify Regular and Reserve Force veterans in Canada and help inform future policy and programs.
- ***Military Equipment*** – our military faces unacceptable delays in acquiring or renewing the equipment they need. This can put our troops at a disadvantage and we ask that they receive the modern resources and support needed to do their jobs well.

RESEARCH & THERAPIES

We are calling for increased research and support in areas that affect our veterans' overall well-being.

- ***Cannabinoid therapy*** – while cannabis may be legal to use, there is little to no research available for veterans or medical practitioners who are considering this sort of therapy. We are asking for targeted research including an investigation into the monitoring and standards related to cannabinoid therapy, and the drug's therapeutic efficacy.
- ***Mefloquine (Lariam) toxicity*** – we continue to question why mefloquine remains a viable alternative as an anti-malarial drug and are advocating for more research into its use and long term consequences, in particular as it pertains to veterans who received this drug when deployed. We want affected individuals to receive proper diagnosis, care and tailored support.
- ***Operational Stress Injuries*** – we are calling for more research into the causes, impact and treatment of operational stress injuries, including traumatic brain injuries in our military forces and their families. In addition, our government must continue working to eliminate mental health stigma in the military and police communities.

- **Service Dogs** - The Legion is still waiting for a set of standards for service dogs – whether created nationally, by the Government of Canada, or departmentally. We want service animals trained to a high standard. For the safety of both the veteran and the dog, we want to ensure a medical professional has recommended the dog, and that the veteran has the required training and financial resources to receive one. The original governmental promise of standards in 2018 was not kept, nor was the later promise of a replacement version. We continue to call for the establishment of these needed standards as soon as possible.

THE VETERANS WELL-BEING ACT/PENSION FOR LIFE

We were encouraged by the improvements within the new Pension for Life program in 2018, but later discouraged by the lack of simplicity for end users trying to understand how it affects them personally.

- **Clarity** – veterans need additional details, and plain simple language to understand how they are individually affected by the new Pension for Life program. With that clarity, our Branch and Command Service Officers across the country can then explain the new rules to the many veterans who seek our advice and support in preparing their claims.
- **Family and Caregiver support** – we are pushing for increased support for family and/or caregivers in the form of better financial compensation. We would like to see the establishment of a menu of financial compensation based on lost wages and the degree of disability of the veteran. We would also like to see funding for respite care. We propose that access to Military Family Resource Centres be expanded to include *all* veterans and their families post service.
- **Act modification** – we request renewed assurance that the *Veterans Well-being Act* remains an “evergreen” document, flexible to change as new information comes to light, as originally promised.

VETERANS AFFAIRS CANADA AND THE DEPARTMENT OF NATIONAL DEFENCE

We ask that the following items related to departmental mandate letters be addressed as soon as possible.

- **Collaboration** - we want to see tangible evidence of a collaborative effort between Veterans Affairs Canada and the Department of National Defence to synchronize programs, especially when it comes to the transition of veterans to civilian life; but also to reduce overall complexity, overhaul service delivery, and strengthen partnerships between the two departments – as set out in the departmental mandate letters.
- **Centre for Excellence** – in 2018 we were pleased to see the announcement of the first (virtual) centre of excellence in mental health to enhance research and best practices. We want to see a second centre established soon, concentrating on the identified area of greatest need.

- **Wait times** – the immense backlog of claims processing is well known. Providing veterans with an average wait time is not acceptable and must change immediately with a more streamlined process and additional adjudicators.
- **Marriage after 60** - We would like to see the elimination of the “marriage after 60” claw back clause, so that surviving spouses of veterans who happened to be married after the age of 60, still receive the appropriate pension and health benefits they deserve.
- **Communication** – we ask for better communication overall with veterans about the benefits and services to which they are entitled, and better clearer instructions in terms of how to access them.

**REPORT OF THE TUBERCULOUS VETERANS SECTION
TO DOMINION EXECUTIVE COUNCIL
13-14 APRIL 2018**

TVS National accomplishments membership growth strategies:

Membership

As with all areas of the legion, membership remains our primary focus. We have initiated the following activities to help grow our membership.

Honorary Patron

National TVS has enlisted the help of Honorary Grand President, Larry Murray to find an Honorary Patron for our organization. This is not an easy task and we continue our search and appreciate the help of Comrade Larry Murray.

National Registry of Members:

TVS is in the process of forming a National registry of members. This will enable us to directly contact all of our members and keep them up-to-date on all of our initiatives.

Formation of a virtual National TVS Branch: email – tvstvsnational@gmail.com

TVS has a virtual National Branch for those members who wish to join TVS and don't live near one of the three TVS Branch's. Similar to the virtual Dominion Command Branch.

TVS Website: www.tvs-rcl.ca

National TVS is working on a website so that members and the public may easily acquire information about our Special section. We will have a link from the Dominion website and also propose to have a link from each Provincial Command.

Facebook: @TBVSection

TVS now has a Facebook page; Tuberculosis Veterans Section.

Please like us or comment on the page to help us grow our awareness and membership.

World TB Day March 24th

Thanks to Leah O'Neill, TVS will be featured on Social media with some of our history and news items on the good works of the Tuberculous Section. Yes, Tuberculosis is still a thing in Canada and especially in the Inuit community as was recently noted by the Prime Minister and his apology to the Inuit for past injustices.

Community Philanthropy

TVS Branches continue to volunteer in the community and sponsor the following:

- Supporting Veterans and seniors in the community, especially those needing assistance with respiratory issues.
- Tuberculosis and Respiratory research

- Fund Respiratory equipment for Hospital and First Responders
- Provide Education Awards for students studying Respiratory Therapy
- Supporting Cadets

Provincial Conventions

TVS has made arrangements to have a display booth at the British Columbia, Alberta and Saskatchewan conventions where we will promote our organization to gain new members and offer a greater understanding of Special Sections.

TVS Past President Medal

Where is the TVS Medal? By whose authority was it discontinued?

Special Sections / General By-laws update:

It is vitally important to continuously update the by-laws to bring Special Sections in line with the General by-laws, thereby giving Special Sections equal status to Provincial Commands.

The following by-laws have been passed or are under review by the Constitution and Laws Committee.

Amendments to General bylaws that pertain to Special Sections: Section 1205.

Passed at convention 2018

The constitution and Laws committee of Dominion Command have met to discuss General by-Law changes that affect the special sections as follows:

AMENDMENT – GBL 304.E. AND 304.F.

Discussion focused on the need to better define the process for complaints lodged against Presidents or officers of Special Sections as it would be inappropriate to have a complaint against a Special Section President (or officers) lodged at the branch to which they may belong.

CONSENSUS: It was recommended that GBL 304.e. be amended to add reference to officers of a Special Section.

CONSENSUS: It was recommended that GBL 304.f. be amended to add reference to a President of a Special Section.

By-Law 137.g. AUTHORITY OF SPECIAL SECTIONS

Acting on the suggestion of Comrade Merola, President of TVS, members considered a revision to GBL 137 to give the National Presidents of TVS and OSI the same authority as a Provincial Command President; this authority has already been extended to International Zone Commanders in GBL 708.

CONSENSUS: It was recommended to insert the following as GBL 137.g. The National President of a Special Section may, after enquiry and for cause clearly stated, suspend the charter or powers of any Special Section branch or auxiliary, or suspend any officer thereof or take any other action not inconsistent with these By- Laws that is necessary or advisable for the good of the Legion, and shall report to Dominion Command upon the action taken.

Yours in Comradeship
Kandys Merola
National TVS President

**REPORT OF THE OSI SPECIAL SECTION
TO DOMINION EXECUTIVE COUNCIL
13-14 APRIL 2018**

Mental Health First Aid (MHFA) - Last year we coordinated/arranged nearly 70 serials of Mental Health First Aid (MHFA) for the Veteran Community, training over 1300 Veterans, family members, and supporters. We submitted a proposal to VAC for continued funding for courses in 2019/20. VAC have agreed to fund 50 more serials for the veteran community at-large in addition to serials for the CAF through the MFRCs, commencing 1 Apr 19. We have already booked serials in Osgoode, Calgary and Niagara and welcome offers to host serials in rural and more remote communities.

ThoughtSpot - Last year, we encouraged the Centre for Addictions and Mental Health (CAMH) to adapt their very successful mobile app that was developed to crowdsource mental health support for at risk teens to meet the requirements of the Veteran Community. The CAMH project team was very enthusiastic to take this on and made a submission for funding under the Veteran and Family Well-Being Fund. While the proposal (named CommandPost) was unsuccessful for 2018/19, we were encouraged by VAC to revise and resubmit the proposal this year. We collaborated with CAMH and resubmitted the proposal 29 March 19. If successful, this will see a mobile app adapted to give Veterans immediate access to information about mental health services and resources in their proximity.

Project Trauma Support (PTS) - We have been working with Project Trauma Support to improve governance and accountability and to encourage Veterans who are in need and eligible for support to seek help through this innovative, residential healing program.

Suicide Prevention - We are represented on the CIMVR Suicide Prevention Steering Committee, shaping the workshop to be conducted in May.

Operation VetBuild - The pilot site for OpVetBuild is Ajax Branch 322 starting April 21. The second site will be Edmonton Branch 175 in June. More branches will be added. Full briefing note on Operation VetBuild is attached.

Strategic Planning - A strategy/ planning weekend was held 30/31 March in Angus, ON by the Executive of the Section, including the President Elect as an advisor. This was the first "in-person" meeting of the executive since ratification. Following the opening of the meeting, a Land acknowledgement, tobacco gift and smudging ceremony took place.

Key decisions coming from the meeting are:

- the four Vice Presidents have been assigned key areas of responsibility
- a review and update of bylaws will be conducted
- a review and update of the strategic plan will be conducted
- committees will be formed on key areas related to OSIs, including MST and LGBTQ2

Yours in service,
Christopher E. Richardson



Royal Canadian Legion OSI Special Section

Operation VetBuild

Scope:

At the request of Legion House, BSO Legion OSI has begun the planning steps to run a veteran to veteran peer support program that uses model building as its medium. This program has been named Operation VetBuild. The word Operation implies a task or mission to be carried out by the veterans. VetBuild has a double meaning. Vet implies who will participate in the program, meaning veterans. Build implies the construction of models and the building of confidence of the veterans.

Clinical studies suggest that engaging in hobby helps build coping mechanisms to deal with depression, anxiety, OSIs and PTSD. In Great Britain and the United States, Models 4 Heroes and Models For Troops respectively use model building as a means of healing for veterans. In the UK, there are approximately 200 veterans that benefit from the program nationally. The aspects of these program enable veterans to meet in a social setting with other veterans that leads to conversations and bonding while engaging in hobby. Here in Canada, there is no program that uses model building as a medium for healing and social support. Operation VetBuild will be the first of its kind in Canada.

Intent:

Operation VetBuild has been in the planning stages since January 2019. Our intent is to launch a pilot program that will be a joint venture between BSO Legion OSI and Branch 322 in Ajax Ontario on the 21st of April, 2019. This pilot will shape out the rules and guidelines in which the program will operate and will establish best practices. It is estimated that by June, 2019, we will be able to launch our 2nd location, Branch 175 Kingsway in Edmonton, Alberta. This 2nd launch will confirm that the rules and guidelines work in practice and allow for modifications before the 3rd launch in the fall of 2019. Calgary AB, Hamilton ON, Georgetown ON, Winnipeg MB, Brandon MB are slated for 3rd launch. After the 3rd launch, other locations will make themselves known as the program proceeds and will be taken on based on the established criteria that we set out. There will also be a media roll out of the program in June and potentially a second media bit in November during the days leading to Remembrance Day

Conduct:

VetBuild locations will be run in Legion Branches that have suitable facilities such as a room capable of hosting 10 to 20 veterans engaging in model building that is separate from the club room. VetBuild team leaders will be a veteran, a member of that branch, a member of BSO Legion OSI, be a model builder capable of assisting others in the hobby and have at a minimum, the mental health first aid course. If they do not have MFHA, they must be willing to attend one at the earliest convenience.

VetBuild team leaders will be responsible to:

- Coordinate and book the meeting space with their branch,
- Organize model kit/supply donation drives and solicit support from their community,
- Create partnerships within the greater model building community,

- Report donation collections to BSO Legion OSI on a quarterly basis,
- Submit requests to their branch or higher command for the use of poppy funds,
- Ensure a safe environment for both the participants and themselves,
- Be patient, creative and willing to have fun.

Participants will be those who are:

- A veteran of the Canadian Armed Forces, Allied Veterans, RCMP,
- Be a client of VAC or equivalent or be fully retired,
- Or a child or spouse of a participating veteran.

We will also look at tying in the mental health first aid course into VetBuild. Once there is sufficient numbers to host an MFHA event, BSO Legion OSI will coordinate the event for them. The benefit to this is that after the MFHA course is complete, the majority of the attendees will be able to maintain contact through Operation VetBuild that will be of a greater benefit in supporting each other with the right tools.

We will be seeking a marketing venture in partnership with Legion House to roll out Operation VetBuild merchandise. It would be requested that a portion of the sales of the merchandise would go directly to Operation VetBuild and the remainder going to Legion House to cover off the leg work involved in managing the inventory through the Poppy Store. This merchandise would also be sold at model building conventions across the country to help promote the program.

At least for now, Operation VetBuild will use model building as its medium. In the future and based on the interests of veterans in certain areas, the program could adapt to other mediums such as fly tying, painting, etc. to suit specific needs or wants.

We will not actively engage participants in soliciting membership into the Legion. This program is for them and not us. However, we have seen a small spike in membership in BSO Legion OSI and we have been informed that some veterans have joined the Legion so that they can help with the program. So, the by-product of running a good program that caters to veterans is that we will see at least some of them join without being asked. But if they don't we have still fulfilled our mandate.

Summary:

To date, Operation has secured well over 250 model kits as well as model building supplies between Ajax and Edmonton with more and more on the way. These donations equate to a value of approximately \$6000 to date with no immediate signs of slow down. The positive feedback and support that we have received has been overwhelming. With the leadership of BSO Legion OSI and the support of the poppy fund in conjunction with donations, we will have a strong program focused on supporting veterans and demonstrating the Legion's ability to continually adapt to an ever changing environment.

Craig Hood CD

BSO Legion OSI Special Projects Chair/

Operation VetBuild National Coordinator/Founder

**REPORT OF BC/YT PROVINCIAL COMMAND
TO DOMINION EXECUTIVE COUNCIL
13-14 APRIL 2018**

The following is my report on behalf of BC/Yukon Command.

Trusteeship

The Trustees have been working hard with the Executive and staff of the Command and Command Headquarters to move the Command forward. Command is now operating in a direction the Trustees were hoping for. Dominion Command asked for the BC Command to be brought back to an operating system that has the potential of BC Command becoming one of the leading commands again. The elected officers and a very dedicated staff should be proud of what has been accomplished to date.

Most committees are working well and have the support of the Trustees to continue in their current manner.

Branch Advisory

BC/Yukon Command has always worked closely with our branches to ensure their future, and this year is no exception. We continue to provide a staff resource in the form of Branch Operations Advisors, who work throughout the BC/Yukon area and provide direct support to branches in the form of advice and information on bar and kitchen operations. Branch financial reports show an increase in branch efficiencies during the time the program has been in effect.

Within the committee level, we have instituted a Branch Operations Committee and a Branch Development Committee. Creating a separate committee for branch development allows for greater attention to those branches who have decided to use the value of their real property to secure themselves a long term financial future. As of the end of February we have 16 branches that are actively planning to either sell or redevelop their property.

Legion Veterans Village

Progress continues on this \$60 million+ project, which is the biggest of its kind in Canada. We continue to work with all levels of community partners, interested parties, and of course government to bring this building to reality. The Centre of Excellence in PTSD and Health Services has recruited experienced and devoted tenants including, CBI, OSI, and a group of Doctors which will provide medical, dental and physiotherapy clinical care as well as a pharmacy. B.C Housing has committed to 58 units of residential affordable housing. This project has attracted national attention and we are still hopeful for Federal funding to add more affordable housing. The City of Surrey has named this project a "Nexus" project, and it was fast tracked by the City. The exact date of the groundbreaking will depend on branch relocation and some permitting issues, but we expect it to occur in early May.

Government Relations

The Trustees and the Executive Director have taken steps to strengthen our relationships with the provincial government and local military authorities. They met with the Deputy Premier's staff as well as the Minister of Municipal Affairs and Housing to explore options to provide tax relief to the branches. They met with staff from gaming licensing and gaming enforcement and are in discussions with liquor and Cannabis control and licensing. They have also met with the Commander of CFB Esquimalt and the Commander of Maritime Forces Pacific.

Marketing and Communications

A lot of work and progress has been made in increasing our engagement and outreach. Earlier on in the year we hired a communications consultant to work with staff and executive to come up with a public engagement and outreach strategy, and hired a communications and PR coordinator to work with our PR Committee to begin to execute that strategy. Great progress has been made in realizing the potential of social media, and staff are working on initiatives such as website redesign, remote meetings and training, and member services.

Membership

BC/Yukon Command's paid voting members stood at 46,239 as of the end of 2018, with 70% or 32,948 having renewed for 2019. Our membership committees at Command and branch level have been working on email and phone campaigns to encourage quick renewals. We are aggressively pushing the use of the Dominion membership portal.

Training

BC/Yukon Command has identified a significant gap in the knowledge and experience of our members at the branch and zone levels, and are working to put a program in place to close that gap. A program has been put in place where Command executive and staff will deliver training to Zone meetings, visiting each of the 18 zones once every other year. Zone commanders will continue to receive training at each PEC, and workshops will continue for delegates at Convention. A program is being developed to make training materials available remotely, either as videos that can be viewed on Youtube, or remotely in real time using Skype or a similar application.

Veterans and Seniors Services

BC/Yukon has had 100% turnover of Command Service Officers this year, but our new additions are working hard and making great progress providing support to our veterans and assisting our branch service officers.

We have had a few instances of alleged Stolen Valour over the past year, and have developed a policy for branches to give them some guidance for future allegations. We

are trying to balance the need to protect the integrity of the Legion against the need to respect our members' right to due process, and we believe that this policy strikes that balance.

Conclusion

It has been an eventful year at BC/Yukon Command, and great progress is being made. In light of all the recent changes, we are still in a very successful operational mode. The Trustees are becoming more comfortable in the operations at Command level, although we must emphasize that we are still ultimately responsible for the operation of the Command. Relationships between Provincial Command and branches are improving.

Respectfully submitted,

Michael Cook
Chair
Board of Trustees

**REPORT OF AB-NT PROVINCIAL COMMAND
TO DOMINION EXECUTIVE COUNCIL
13-14 APRIL 2018**

Comrades

After a successful election for a second term as President of Alberta-NWT Command my mandate was to try to develop more of our Council members and members in general. It is far too easy to get into the day to day problems Branches have. Many times, it is personality conflicts, or the issue of passion and misunderstanding. Instead of focusing on personal agendas we need to work for The Legion. I hope to use my second term to make The Legion better. I would like to start with affirming that we are all one organization. It can be felt in our Command; there is a line of them and us, not only at the Branch and Provincial Command Levels but also between Dominion Command and Provincial Command. The passion I see from all of us sometimes gets in the way of unity and common sense. If there is one thing I can say I learned, it is that we need to listen to each other and work together. It is ok to have opinions and ask questions but it also important to listen to those opinions and consider the questions.

During the last 2 years we have had our share of problems and I would like to highlight a couple of them.

In regards to the Calgary and Edmonton amalgamated branch poppy funds, Steps were taken to prevent further misuse of funds while we considered all options for the Calgary Branches Poppy Fund. All clients requesting assistance are required to provide financial standing and fill out the Legion Claim form. This process has provided over 150 Veterans with significant assistance from Veterans Affairs. Happy to say that through some outstanding work by Tammy and her staff both Calgary and Edmonton amalgamated branch poppy funds are running under proper means with all staff and overheads eliminated. The last process is the sale of the Edmonton office which we hope to see completed by June, the office is currently housing the Edmonton service bureau.

Another issue that has reared its head is over trustees of a branch. We have been dealing with a very large branch in Calgary where we have had trustees in place for 18 months. We believe we need a better system in place to help all commands when a branch is in need of help. This particular branch although large in membership is lacking standard business practices which is putting the branch under great financial stress. Comrades Clark and Rycroft have been assisting us as this branch remains unstable.

The AB/NWT Command is in full support of having some clear processes in place to deal with the stolen valor issue. Our command has dealt with 2 of these complaints, but without a direct policy has caused some issues with the branches dealing with them.

I look forward to catching up with everyone in Saskatoon

Respectfully submitted
Chris Strong
President AB/NWT Command

**REPORT OF SK PROVINCIAL COMMAND
TO DOMINION EXECUTIVE COUNCIL
13-14 APRIL 2018**

Comrades,

I bring greetings on behalf of Saskatchewan Command officers and members. As with most of you, this will be my last report to DEC. I thank each and everyone of you for your guidance and wisdom over the term of my Presidency. Our Provincial Convention will be held in October in Moose Jaw.

Saskatchewan Command continues to work at obtaining branch rates for the online portal. We are down to under 20 branches now. The last few are proving to be elusive. A couple of those branches are not active and are in the process of closing. Our membership chair is being very proactive in contacting the zone and district commanders to encourage them to reach out on new members and renewals.

The sports program has somewhat stayed the same in terms of participation. We did make some changes in how they are run. In golf we reduced the number of flights, moved bowling to the fall to separate it away from the rest of the other events. We made a decision to continue Curling within the Provincial and have been surprised by the growth in the number of teams entering. We opened up Curling last year to allow players from any district to play on the same team which may have contributed to the growth.

Saskatchewan Command continues with a Provincial Camp for Track and Field. We will have to host in a different city as the University of Saskatchewan's track is being torn down and the new one will not be ready by July. The committee is working on different arrangements now.

Saskatchewan Command has added a new position. We now have a part time, paid position in the Service Office. The need arose from the increase in traffic and the number of veterans coming to the office.

We are currently working on two new programs to help veterans. A wellness program was approved at our last PEC meeting. The program will be initially geared towards physical health and wellness. The program will be reviewed in a couple of years to ensure it is what is needed. We are trying to encourage the use of physical health as a means of healing and a tool for coping with the various struggles that veterans go through.

Saskatchewan Command has placed one of our service officers through the Mental Health First Aid for Veterans facilitators course. He has already made trips to Winnipeg and Dundurn to facilitate a course. Once he facilitates one more course, he will be fully certified and will be able to offer courses throughout the province and the prairie's as we require.

We continue to build our following on social media. With the help of the Dominion public relations department we have been able to make use of their suggestions. This has helped us greatly in terms of reaching out to more people.

We ran a RED Shirt Friday campaign to promote support for all Canadian troops. We sold over 700 shirts in just a few months. It was a basic red t-shirt with our logo on the front and a nice design on the back (R.remember E.everyone D deployed). We also made a few zip-up hoodies to add to the collection. I felt very strongly that we needed to carry on this campaign of Red Shirt Friday to show our continuing support for the troops.

The next few months will be quite busy for our Command staff and council. We have purchased a new building for the Command Office. We will be relocating there, which means, some renovations at the new building, packing and cleaning out the old building at the same time as getting ready for Convention and Poppy Campaign.

I respectfully submit this report.

Lorne Varga

**REPORT OF MB & NWO PROVINCIAL COMMAND
TO DOMINION EXECUTIVE COUNCIL
13-14 APRIL 2018**

Comrade Chair, Comrades;

I bring you greetings from Manitoba and Northwestern Ontario Command and its Executive Council members.

Membership/Branches: The Command total for the 2018 yearend membership has 131 branches reporting a membership of 21,070 down from the 21,797. As of yearend, of our 131 branches 32 of them achieved 100% or better for paid membership. The largest gain with members over 100 was Gladstone Branch # 110 with 49 new members. The largest gain for branches under 100 was Robert Frost Branch #133 with 25 new members.

Poppy Campaign: We had 123 branches involved, with 122 reporting, in our recent campaign. Income was up slightly over last year. The statistics from the Poster & Literary Contest are up over the previous year with 58 branches reported having a total of 5,063 entries which is an amazing 77% increase over last year!

CLL Committee chairman reports that last year the Committee reviewed a list of all approved Branch By-Laws that Command had on file. The Committee noticed that many Branches had not submitted a copy of their By-laws or there were many Branches that had not reviewed or amended their By-Laws for more than 10 years. So a letter was sent to all Branches requesting them to review their By-Laws and inform the Command office or CLL Chair about the status of the By-Laws. 75% of the Branches have responded with a copy of their By-laws or a letter stating they will review and submit amended By-Laws for approval.

Now we are finding that some Branches did not provide the proper documentation for the CLL to review. When this happens the Command office contacts the Branch requesting the documents. This delays the process therefore the committee is in the process of creating a sample package to be sent to the Branches to assist them to follow proper procedure and provide documents so the Command can approve the By-Laws amendments quickly.

10 Branches have been approved with 7 Branches in the process of being approved.

Sports: The chart below reveals that branch participation is decreasing even in Cribbage and Darts. We have had to cancel 8-Ball for two years due to lack of entries. Only two branches registered in 2019.

Event	Year	# of Br	# of Team	Doubles	Singles
8-Ball	2015	10	11		
8-Ball	2016	4	5		
8-Ball	2017	Cancelled			
8-Ball	2018	Cancelled			

8-Ball	2019	3		4	
Darts	2015	21	26	48	62
Darts	2016	25	28	53	71
Darts	2017	22	25	51	71
Darts	2018	22	23	46	57
Darts	2019	22	23	45	68
Crib	2015	40	52	102	157
Crib	2016	39	50	101	142
Crib	2017	36	44	95	133
Crib	2018	34	42	86	116
Crib	2019	37	41	87	135

Public Relations: St. James Branch hosted the Legion portion of the Amazing Race Canada where the participants competed in a game of darts in order to advance to the next event. This branch also hosted the launch of Legion Lager in Manitoba.

On October 15, I had the privilege of being a special guest and represented the Legion at the Unveiling of the Armistice \$2 Coin at the Royal Canadian Mint.

Leading up to and during Remembrance Week local nostalgia radio station CJNU played many Legion and Remembrance Day PSA's. As well I had the wonderful opportunity to participate as a guest DJ and discuss the Royal Canadian Legion and Remembrance. They also broadcasted live from the Victoria Hospital for their Remembrance Service.

On Remembrance Day, our Command was once again involved with the CTV Live Morning Show broadcast from our St. James Branch #4. Live Interviews were conducted with Veterans, serving members and legion members.

Many branches across the command participated in the Bells of Peace program and many also laid Canadian Flags at the graves of WW1 veterans leading up to Remembrance Day.

12th Annual Yellow Ribbon Gala - for the seventh straight year our Command purchased a table of 10 in support of the Military Family Resource Centre. We feel it important that we must show our support and be a presence at such events. A good time was had by all in attendance.

To further increase the Legion presence we will once again be a Silver Sponsor at the upcoming Annual RCAF Run - June 2019 in Winnipeg.

Youth: We awarded 43 Cadet Medal of Excellence Awards in 2018.

The Legion Athletic Camp at the International Peace Garden saw a slight decrease in attendance. In total 411 athletes competed in 2018. There were 417 athletes in 2017 and 443 in 2016. The camp ran seven sports over a period of 4 weeks.

I had the pleasure once again of attending the Legion National Track & Field Championships in Brandon Manitoba. Brandon Branch No. 3 did a great job and I was honoured to present medals to some of the winners.

Military Service Recognition Book: Our friends at Fenety Marketing are currently working on Volume 10. This book continues to be a very good source of income for our Command.

Veterans Services & Legion Seniors: Canadian Legion Memorial Housing Foundation continues to provide affordable housing to our veterans and/or their spouses or widows/widowers. The housing also provides accommodation to homeless veterans while they search for long term solutions.

In December our Command Service Officer held a Branch Service Officer Training seminar which was the best attended in many years.

47th Dominion Convention: Our LAC Committee under the chairmanship of Comrade Rick Bennett worked very hard to put on a hugely successful Dominion Convention.

In Comradeship,

Ronn Anderson
President

**REPORT OF ON PROVINCIAL COMMAND
TO DOMINION EXECUTIVE COUNCIL
13-14 APRIL 2018**

Comrade Chairman, Comrade Grand President Larry, Comrade Dominion President Tom, Comrades All,

It is a pleasure to provide a brief summary of happenings in Ontario Command, this past year. Anticipating updates from Districts at our March Provincial Admin, I planned to compose my report during vacation, carted my laptop with files, to Puerta Plata. Three days prior to the due date, confined as a storm hovered above, I thanked Mother Nature for an opportunity to not waste sunshine while compiling this report.

CONVENTION 2019

At convention 2017, in London, Oshawa Branch 43 bid to host the 2019 Convention. Unfortunately, in October of 2017, lack of progress on the construction of a new Convention Centre caused the branch to withdraw their bid. This left us without a location. We approached our Comrades in Niagara Falls, who had hosted a great convention in 2015.

Historically, our Provincial Convention has been held Mother's Day weekend, members often complained about the conflict. Our Constitution & Laws Chairman, among the vocal ones, proposed as Dominion Convention had moved from Father's Day, and given Ontario had a female President, this was the year to make change! In response to our request for a host, Niagara Falls LAC said if we could move the convention forward a week, they would host. This was the deciding factor! The change of date and venue was approved by the Provincial Executive Council in November 2017. The change lead to a few complaints and complications, life goes on, and so must we!

Our YouthEd Committee agreed to hold Provincial Public Speaking in Niagara Falls, rather than Timmins, which presented an added attraction for delegates. Anyone planning to attend Ontario's Convention is encouraged to arrive Friday or early Saturday to witness this competition, you will be amazed!

The apprehension over the date change has passed, as our LAC advises they have met our contractual obligation on room quota, and with that concern resolved, are now able to concentrate on planning a great convention for all!

VETERANS SERVICES/HOMELESS

The Ontario Command Homeless Veterans Program to date has assisted over 710 clients, including 70 females, one American and one Quebec Veteran, in 147 different communities, expending over 2.3 million dollars.

Our VS/Homeless Chairman has initiated contact with the RCMP, Ontario Chiefs of Police Association and the Ontario Provincial Police, to introduce a program aimed at identifying Homeless Veterans sooner, to potentially get them to 'Leave the Streets Behind'.

As well, our Chairman has initiated contact with the VSS Chairman of Manitoba/Northwest Ontario Command to support the Leave the Streets Behind Program for all Ontario Veterans.

In 2016, we introduced a Dental Program for Homeless Veterans partnering with George Brown Dental College, in Toronto. In 2018, a similar program was introduced at St Joseph's Healthcare Facility in London.

Our Provincial Service Officers each conduct a Workshop/Seminar each year for Branch, Zone and District Service Officers. This year there are to be sessions in June to train new BSOs on proper form completion.

A motion was made at PEC in November, that Ontario Command donate \$100,000 to the Ottawa Multi-Faith Housing Project, planning to break ground this Spring, will go to the convention floor in May for approval.

MSRB & POPPY

The success of our Military Service Recognition Book has provided the opportunity to support additional programs for Veterans, to those currently supported thru Poppy Trust Funds. As the funds raised are from submissions of Veterans, the proceeds should be used to benefit Veterans. With many innovative new programs being introduced to assist Veterans through transition, these funds are being dedicated to sponsoring more transition programs.

In April 2018, Ontario Command lifted the moratorium on Poppy Funds, which prevented use of funds by branches for Service Dogs. In July, at Little Current Ontario, we officially kicked off **Operation Service Dog**. Just like expectant parents, we anxiously await delivery of the first OSD puppy, now scheduled for Provincial Convention.

SENIORS

Our Seniors Chairman suggests that a better fit for this committee would be Membership, rather than Veterans Services, given the greatest percentage of our members are over 55.

Some of you may recall the poem written by a Dutch Canadian senior shared last Remembrance Campaign, in which she expressed her gratitude to the Canadian forces of WWII. Our Seniors Chairman was inspired by the poem. With an enthused committee, they created a Literary Contest for Seniors, patterned after the YouthEd literary program, which is being piloted by two branches in smaller communities with a senior population. The proposal was positively received by our Admin Comm.

This program could be a **membership initiative**, as noted above, with the largest segment of our population nationally in the over 55 age group, there is a tremendous potential. It is hoped that existing members will promote the competition among their circle of friends, and as a result inspire interest in other programs the branch and our organization offer. The competition deadline for entries is May 24, with awards scheduled for June 'Seniors' Month' in Ontario. We appreciate it will take time, however, we perceive the program could expand to include art and photography. As this is the first program introduced for members of late, the potential is exciting.

BRANCH NEWS

Our Constitution & Laws Committee is putting forward Amendments to Provincial By-Laws to the delegates at Convention, which will provide branches the opportunity to use electronic funds transfer for specific transactions, finally, moving forward as we enter the third decade of this 21st Century!

The Ontario Command Website is updated on a regular basis, providing a variety of printable forms, documents and info brochures, from many committees. Our Leadership Development Team created back to basics pamphlets on branch operations, finances, Executive roles, etc. Our C&L provided Guidelines with fillable forms for Branches to complete Clubhouse Rules, and Policy and Procedure Manuals. Several manuals are available for online reading only. Hard copies are available for purchase at a reasonable price.

One of our commitments made to the membership is an updated Officer's Manual. Last revised in 2012, updates have been recently completed by our Standing Chairmen with Committee input. Each segment submitted is being proofed, readied to move into the formatting stage. The full package will be sold in loose sheets for three-hole punch, updates will be free and printable for insert into binders. Unfortunately, other commitments for Provincial Convention scheduled for the first weekend in May, have moved printing of the manual to the end of the queue given we have our Convention books and all Convention related material to print as a priority. However, if not ready for convention, though a disappointment, it will be available soon after. Given the last edition took ten years to revise, having spent only two years, with so many changes, I'd say, we're doing fine!

There are 7 Boards of Trustees in place in Ontario, at the time of this report. In two branches, the BoTs were ready to pull out, the Branch Presidents were not co-operating with the Board, totally frustrating all involved! As a result, in one situation, at the request of the District, I was forced to invoke GBLs Section 418a.

ARTICLE III

Our organization was founded on Comradeship, at initiation, we swear to uphold. What has happened to that spirit and the good intention of the handshake!? The Article III process can be a valuable tool, when understood and used as intended. It should be

appreciated, not abused. At the time of this report, we have one branch, that has had 65 Article IIIs, each involving the same member, directly or indirectly. The complaints are lodged on issues or concerns which one would anticipate normal mature adults could agree to disagree and move forward, all having learned something in the process. As I sit here now, writing this report, it wouldn't surprise me to have another to consider when I get home!

SPORTS

At the beginning of the term, concerned that our Provincial Sports Program was repeatedly operating at a loss, options were considered. As Host Districts were conducting the provincial tournaments, instead of the Provincial Sports Chairman travelling across Ontario to do opening, closing and present awards, the nearest Senior Officer attends. As well, registration fees were increased for the majority of sports, most had not seen an increase in over 30 years. These couple of changes put the program well into the black at the end of the sports season.

TRACK & FIELD

Eliminating the Winter Indoor Meet a couple of years ago, freed funds to increase the number of athletes we could afford to sponsor. As well, our PEC approved sponsoring a 3rd coach. We were fortunate to recruit a coach, who is a physiotherapist to go with the team to Nationals! Truly a bonus for our Team O athletes! We had a young group of competitors last August in Brandon, though they fared well, we are looking forward to outstanding results in Sydney!

PROPERTY

Over 10 years ago, Cobourg Branch entered into an agreement with a developer, for a condo development on their branch property. Finally, the shovel is in the ground and construction is underway. Comrade Brian, our OC Property Chairman, living in the community, does regular checks on the progress of this development.

Branch 11 recently entered into an agreement with a condo developer in a high density area of East End Toronto. The branch negotiated well, receiving kudos and full support of our property committee to move forward.

Another Branch, which we heard here, last spring, were well into development discussions, when finally contacted, they didn't understand the By-Laws and why there are rules to follow. We do agree their plans are excellent and would benefit the community, should they come to fruition.

In closing, Comrades, with a great crew of Officers, and awesome Staff support, I'm proud to boast our Team 'O' is the best. Serving as Provincial President has had its good, bad and ugly moments, but, overall, it has been an enjoyable experience, which will soon be at an end. It has been a pleasure, for my husband Bill and I, to meet each of you, to have

shared comradeship when possible, and worked together for the betterment of our organization. We wish you success in your future endeavours!

In Comradeship,

Sharon McKeown
Provincial President

**REPORT OF QC PROVINCIAL COMMAND
TO DOMINION EXECUTIVE COUNCIL
13-14 APRIL 2018**

RAPPORT DU PRÉSIDENT – DIRECTION DU QUÉBEC

Camarades peu de changements dans la routine de la Direction. Continuer avec mes confrères au provincial de prendre des actions qui devraient être bénéfique dans un futur rapproché. Ces actions sont :

- a. Prendre et appliquer des décisions qui concerne les opérations journalières de la Direction provinciale;
- b. **Continuer de visiter le maximum de filiales** afin de démontrer que le provincial est présent et a leurs intérêts à cœur. Ceci comprend : assister aux assemblées générales et les réunions des comités exécutifs, assister aux cérémonies commémoratives et dîners des vétérans, donner des discours les félicitant pour leurs travaux, et leurs expliquer les règlements de la Légion afin qu'ils puissent les appliquer correctement;
- c. Lorsque la situation et le commandant de district et/ou président d'une filiale le demandait, se présenter à la filiale afin de connaître la situation et trouver des solutions aux problèmes. Nous avons aussi tenu des réunions au bureau provincial;
- d. Continuer de rencontrer diverses organisations donc la Légion travaille avec dans le but d'identifier les besoins de chacun, améliorer les relations, et de planifier et gérer des programmes communs. Quelqu'une de ces organisations sont le Fonds du Souvenir, Vétérans NU/OTAN (UN/NATO), Anciens Combattants Canada et Fondation des Vétérans du Québec;
- e. Continuer de participer et prendre un rôle actif aux rencontres organisés par le groupe **RESPECT**. Ces rencontres ont pour but de répertorier les organismes de bienfaisance qui offre des services aux vétérans et leurs proches incluant ceux privés (OSBL) et public tel que Vétérans dans la rue et Centre de soutien à la famille de la Défence nationale afin d'offrir un meilleur service aux vétérans, leurs proches et les militaires encore actifs. Une première au Canada, participer au **Grand Rassemblement des VÉTÉRANS** le 29 septembre 2018 à St-Hubert ou plus de 30 organismes de soutien aux vétérans étaient présent. Plusieurs vétérans sont venus à l'événement

- f. **Être plus présent dans les médias.** Continuer de donner des entrevues dans des journaux, parlé sur les stations de radios (CKVL) et été présent dans plusieurs cérémonies commémoratives ou les médias étaient présent;
- g. **Élaborer un plan d'action commun** – Création d'un sous-comité provincial sur les vétérans avec un rapport dû pour le congrès provincial en mai. Le comité n'a jamais pris son envol et c'est à revoir;
- h. **Cours de leadership** : Pas de finance pour soutenir un cours de leadership alors j'ai pris l'Option B qui est que le président provincial donne des présentations POWERPOINT de 2h30 dans chaque district aux exécutifs des districts et des filiales. Couvre les sujets suivants : statuts et règlements; procédure de plainte, obligations et pouvoirs des membres du provincial, des districts et des filiales; et leadership. La première présentation a eu lieu au District 4 Québec le 16 septembre 2018 et une autre le 20 février 2019 la la Filiale 034 Arras (Chambly).
- i. **Cours de santé mentale** : Continuons a donner des cours dans les filiales ciblées ou il y a beaucoup de vétérans avec le PTSD telles que Rosemont, St-Jérôme et Québec. Le cours est pour les personnes en contact journalier avec ceux atteint du PTSD tel que les membres de la famille immédiate et les officiers d'entraide. J'ai suivi le cours donné le 22-23 novembre 2018 à St-Jean;
- j. **Modifier les statuts** : À part de corriger la grammaire dans les deux langues officielles, il y aurait des modifications a apporter. Ces modifications a être voté par le comité provincial et soumis au national concernant surtout l'Article 3;
- k. **Réunions de la direction provinciale** : Réunion du sous-conseil tenu le 13 octobre 2018 et 23 mars 2019. Beaucoup de sujets couverts et a couvrir, la routine. Le 8 décembre 2018 il y a eu une réunion sur le financement au sein de la direction provinciale et des filiales afin de prendre des décisions qui pressaient, de revoir les revenus et les dépenses et de trouver des solutions pour augmenter les revenus. A part de toujours coupé dans un revenu diminuant, pas de solutions réelles proposées par les membres. Il y a un urgent besoin de changer la mentalité sur le financement au sein du comité et de nos membres en général afin d'assurer la survie financière de la direction provinciale et de nos filiales;
- l. **Comité provincial sur la promotion** : Les bénéfices offerts pour les vétérans et nos membres sont affichées sur notre site web et chaque semaine nous avons des de nouveau partenaires au programme.

Ce qui suit est un résumé de nos diverses activités de comité tout au long de l'année:

Membres / Adhésion : Notre président a continué de travailler avec nos commandants de district afin de augmenter le nombre de membres. Mise en place du programme

stratégique de la Légion.

Constitution et Lois : Renforcement des règlements, plus de professionnalisme demandé à tous et continuation de la révision des statuts au sein du provincial, des districts et des filiales.

Sports : Va éliminer le tournois de golf faute de participants.

Athlétisme : Va avoir 40 personnes participants cette année.

Hôpital Sainte-Anne : Notre comité continue de faire des visites mensuelles à moins de 190 patients. Depuis son passage au ministère de la Santé du Québec, l'hôpital continue de fermer des lits et des étages qui étaient aux vétérans. Des patients, des membres de leur familles et ceux de la Légion se sont plein de la détérioration du service et ceci dans les médias. J'ai parlé avec le ministre ACC, le Premier Ministre du Québec, des membres du parti au pouvoir au niveau national et provincial. Des députés provinciaux avec qui j'ai servi mon promis de faire une enquête ministérielle mais je n'ai rien entendus depuis.

Bureau de service : Nos agents de service sont très occupés toute l'année, ils ont visité quatorze districts en donnant des ateliers de séminaires qui fonctionnent bien. Nous collaborons mieux avec Anciens Combattants Canada. Nous avons perdu un officier d'entraide faute de salaire assez élevé et nous l'avons remplacé avec une personne très compétente.

Sans-abri : La direction provinciale n'a pas de programme comme tel pour les vétérans dans la rue. Il y a plus de 40 organismes avec plusieurs programmes qui s'occupe des vétérans itinérants. Le groupe RESPECT coordonne ces organismes avec des réunions aux trois mois. Les prochaines réunions de coordination du groupe RESPECT sont le 22 mars 2019 à Montréal et le 25 mars 2019 à Québec. Nous sommes en contact permanent avec les refuges à Montréal et ces organismes. La direction provinciale et ses filiales continus de fournir un soutien financier et par ses officiers d'entraides, de l'aide en cas d'urgence. Ces organisations sont : ACC, Fondation Québécoise des Vétérans, Vétérans Canada entre autres. ACC à un programme de réhabilitation des itinérants et travaille avec les filiales dans les villes du Québec donc Sherbrooke. J'ai assisté à plusieurs événements au *Old Brewery Mission* pour appuyer les diverses organisations qui fournissent de l'aide à nos vétérans dans la rue.

Le pourcentage de vétérans dans la rue au Québec à été revue à la baisse et après un recomptage plus rigoureux elle se situe entre 3 et 4 % au lieu de 6 %. Plusieurs itinérants se disaient vétérans mais lorsque approché par les groupes d'aides ceci n'est pas le cas. Ils savent qu'il y a des programmes et de l'argent disponibles pour les vétérans itinérants et ils veulent en bénéficier. D'autres ont honte d'être dans la rue et préfère garder leur métier secret tels que des hommes d'affaires et des dentistes.

Je soumetts donc mon rapport.

Kenneth R. Ouellet, CD
Président provincial, Direction du Québec
Comrades,

Little changes in the day-to-day of the Command. I've continued with my colleagues at the provincial level, to take actions that should be beneficial in the near future. These actions are:

- a. Took and implemented decisions regarding the day-to-day operations of Provincial Command;
- b. Continued to visit as many branches as possible to show that the provincial command is present and has their interests at heart. This includes attending general meetings and executive committee meetings, attending commemorative ceremonies and veterans' dinners, giving speeches commending them for their work, and explaining the Legion's bylaws so they can apply them properly;
- c. When the situation dictated and the district commander and/ or president of a branch asked for it, report to the branch to find out about the situation and find solutions to the problems. Meetings were also held at the provincial office;
- d. Continued to meet various organizations with which the Legion works, with the objective of identifying individual needs, improving relationships, and planning and managing joint programs. Some of these organizations are the Last Post Fund, UN/NATO Veterans, Veterans Affairs Canada and the Veterans Foundation of Quebec;
- e. Continued to participate and take an active role in meetings organized by the **RESPECT** group. The purpose of these meetings is to identify charities that offer services to Veterans and their families, including private (NPO) and public, such as *Vétérans dans la rue* and the National Defense Family Support Center, in order to offer better services to veterans, their loved ones and still serving military members. A first in Canada, we participated in the **Gathering of Veterans Services** held on September 29, 2018, in St-Hubert, where more than 30 veteran support organizations were present. Several veterans were present at this event.
- f. **Be more present in the media.** Continued to give interviews in newspapers, spoke on radio stations (CKVL) and been present in several commemorative ceremonies where the media were present;
- g. **Develop a joint action plan.** Established a Provincial Veterans Subcommittee with a report to be presented at the May Provincial Convention. The Committee has never got off the ground and it is to be reviewed;
- h. **Leadership course:** As the financial situation cannot support a leadership course, I took Option B, which is that the provincial president makes POWERPOINT presentations at the district levels, each lasting two hours and a half, to the respective district and branch executives. The topics to be covered: Statutes & Regulations; grievance procedures; obligations and powers of provincial, district and branch members; and leadership. The first presentation took place at District

#4 Quebec on September 16, 2018; another one was held on February 20, 2019, at branch #034 Arras (Chambly);

- i. **Mental Health Course:** Teaching continues in targeted branches where there are many veterans suffering PTSD, such as Rosemont, St-Jérôme and Quebec City. The course is for people in daily contact with those suffering PTSD, such as immediate family members and Service officers. I took the course given on November 22-23, 2018 in St-Jean;
- j. **Amend the statutes:** Apart from correcting the grammar in both official languages, there are modifications to be made. These modifications will need to be voted on by the provincial committee and submitted to the national level, especially as with regard to Article 3;
- k. **Provincial Exec Meetings:** Subcommittee meetings were held on October 13, 2018 and on March 23, 2019. Many topics were covered and to be covered, routine. A meeting was held on December 8, 2018, on funding within Provincial Command and branches, to take decisions that were pressing, to review revenues and expenditures, and to find ways to increase revenues. Apart from always cutting into decreasing revenues, no real solutions were proposed by the members. There is an urgent need to change the mindset on funding within the committee and among our members in general, in order to ensure the financial survival of provincial command and our branches;
- l. **Provincial Advocacy Committee:** The benefits made available to Veterans and our members are posted on our website and every week we have new partners added to the program.

The following is a summary of our various committees' activities throughout the year:

Membership: Our president continued to work with our District Commanders to increase the number of members. Implementation of the Legion Strategic Program.

Constitution & Laws: Strengthened bylaws, more professionalism expected from all, and continuation of statutes review within provincial, district and branch levels.

Sports: Due to a lack of participants, the golf tournament will be cancelled.

Track & Field: Will have 40 participants this year.

Ste. Anne's Hospital: Our committee continues to make monthly visits to fewer than 190 patients. Since its transfer to the Quebec Ministry of Health, the hospital continues to close beds and floors that were dedicated to veterans. Patients, family members, and the Legion have complained through the media about the deteriorating services. I addressed the issue with the VAC Minister, the Premier of Quebec and members of the ruling parties at the national and provincial levels. MPs with whom I have served with have promised to request a ministerial inquiry, but I have not heard anything since.

Service Bureau: Our Service agents kept busy all year round, visiting 14 districts with well-run seminar workshops. We work better with Veterans Affairs Canada. We lost a service officer due to lack of a high enough salary, and we replaced him with a very competent person.

Homeless: This provincial leadership does not *per se* have a program for homeless veterans. There are more than 40 organizations with several programs that deal with homeless veterans. The RESPECT group coordinates these organizations with meetings held every three months. The next RESPECT coordination meetings are March 22, 2019 in Montreal and March 25, 2019 in Quebec City. We are in constant contact with the Montreal shelters and these other organizations. The provincial command and its branches continue to provide financial support and, through its Service officers, help in case of emergency. Among these organisations are: VAC, la *Fondation québécoise des vétérans*, and *Vétérans Canada*. VAC offers a homeless rehabilitation program and works with branches in Quebec cities, of which Sherbrooke. I attended several events at the Old Brewery Mission to support the various organizations that provide assistance to our veterans on the street.

The percentage of homeless veterans in Quebec has been revised downwards and after a more rigorous recount, it is between 3 and 4% instead of 6%. Many homeless people claimed to be veterans, but when approached by aid groups, that was not the case. They know there are programs and money available for homeless veterans and they want to benefit from it. Others are ashamed to be on the street and prefer to keep their job secret such as businessmen and dentists.

I respectfully submit this report.

Kenneth R. Ouellet, CD
President
Quebec Provincial Command
Royal Canadian Legion

**REPORT OF NB PROVINCIAL COMMAND
TO DOMINION EXECUTIVE COUNCIL
13-14 APRIL 2018**

Comrades All, since our last DEC meeting we are doing a concentrate effort on membership recruitment. We issued a challenge to our 70 branches to recruit new members for 2019. As an incentive for the branch with the most new members the Command will give three prizes. 1st place: \$250.00, 2nd place: \$200.00 and 3th place: \$150.00.

Our Provincial Service Bureau is extremely busy.

On the financial side we are doing extremely well. Our finances are in good shape. Our objective is to ensure the long term financial health of the Command.

We have signed a new 5 year contract with Fenety Marketing Services. The revenue from this annual project is instrumental in support of our many programs that otherwise would not be possible.

Our Spring PEC meeting was at branch # 29 Marble Arch in Plaster Rock on the 5th of April.

We will have two Provincial Service Officer and two Provincial Poppy seminars later in the spring.

We are still dealing with more personality conflicts. It is very time consuming and it involve a lot of resources

Since this will be my last DEC meeting. I would like to thank everyone for your support It was a great honour for me to serve this great organization with such dedicated comrades from across this country. Once again thank you to everyone.

Respectfully Submitted

John Ladouceur
President N.B. Command

**REPORT OF NS/NU PROVINCIAL COMMAND
TO DOMINION EXECUTIVE COUNCIL
13-14 APRIL 2018**

NS/NU Command Membership and Legion Leadership and Development Committees have been highly active in promoting and conducting training on the membership renewal process, accessing information, valuable tools and training through the Legion portal and conducting seminars on every topic from Branch leadership to the use of Poppy Trust Funds. Attracting new Members, retention and renewal of Membership as well as Branch hospitality are top priorities. 100% of NS/NU Command Branches have provided Membership rates to D.C. allowing all Members the option of online renewal.

NS/NU Command remains in a financially stable position. Through careful management NS/NU Command has been able to advance all programming and assist in the success of our Branches.

NS/NU Command's VOP continues to deliver valuable programming, quality of life enhancing initiatives, awareness and educational programming to Veterans and their families, especially those living with the effects of mental health and moral injury.

Programming continues with OSISS, Project Healing Waters, Healing on the Fly and Paws Fur Thought. NS/NU Command also supports art therapy, horticultural therapy as well as stream side fly fishing events.

NS/NU Command Branches are active in all sports and will be represented in each sport at the Dominion Championships again this year. Enthusiasm and excitement is building as Cape Breton Nova Scotia finalizes arrangements to host the 2019/2020 Youth Track and Field event in Sydney.

NS/NU Command and its' Branches continue sponsorship and support of the Cadet movement.

Most unfortunately NS/NU Commands Youth Leadership Training Camp, after 55 continuous years, had to be cancelled in 2018 due to unforeseen liability issues.

NS/NU Command has been most pleased with the information, promotions and public relations, especially position statements, disseminated by National Headquarters. This information has been invaluable in increasing much needed awareness, especially surrounding advocacy within our organization and to the general public.

Delegates representing 102 Branches of The Royal Canadian Legion in Nova Scotia and Nunavut will convene for the 54th biennial Command convention in Windsor May 18-20 2019. We very much look forward to having D.C. 1st VP Brian Weaver join us.

Comrades, it has been a privilege representing Nova Scotia/Nunavut Command at Dominion Executive Council. It has been a pleasure working with you in advancing the goals and objectives of The Royal Canadian Legion.

Respectfully Submitted



Mel Crowe
President
Nova Scotia/Nunavut Command
The Royal Canadian Legion

**REPORT OF PE PROVINCIAL COMMAND
TO DOMINION EXECUTIVE COUNCIL
13-14 APRIL 2018**

- ▶ Since the retirement of PEI Command Executive Director, Betty Maclachlan, command has been struggling to find the right person to fulfill her job. PEI Command has hired Brenda McMillan as our new executive director as of February 1st, 2019. Brenda brings with her a lot of knowledge and seems to be adapting to this position very well.
- ▶ Once again, the legion sports have been well represented by all branches. Provincial playoffs went over really well. Thanks to the provincial sports chairperson, Threasa Gallant.
- ▶ The essay and poster contest were a huge success with a great number of participants from all schools across the province.
- ▶ The VSS Committee held a meeting at Command Office to discuss the concerns of homeless veterans.
- ▶ The Leadership and Development Committee held interviews for the Pilgrimage of Remembrance. Duane MacEwen was the comrade chosen to be representing PEI Command.
- ▶ PEI Command is having its 65th Provincial Convention May 24-25, 2019. Plans are well under way and the committee is doing a great job getting things ready for the convention.
- ▶ The Constitution and Laws Committee has reviewed the PEI Provincial policies and have made several changes to some of the policies.
- ▶ Since this is my last DEC meeting, I would like to thank everyone here for all the wonderful information you passed on to me along the way. I wish everyone at DEC all the best.

Yours in
Comradeship
Stephen Gallant

A handwritten signature in black ink, appearing to read 'Stephen Gallant', written in a cursive style.

President PEI Command

REPORT OF NL PROVINCIAL COMMAND TO DOMINION EXECUTIVE COUNCIL 13-14 APRIL 2018

General

Newfoundland Labrador Command has had a very busy 2018 dealing with several Branches regarding Financial and Administrative problems. At the moment we are on top of all these issues and have placed a Board of Trustees in one Branch. The Command Office staff continuously demonstrate excellent teamwork and have made the operations of the office and our entire Command more efficient.

Branches

We have 45 Branches in our Command and approximately 4,000 members. A few of the Branches run into trouble from time to time and we do the best we can to guide and advise them along the way. We have performed two Complaint Hearings against the President of Branch 50 in Kelligrews and we are hopeful that the complaint committee's penalty of expulsion from the Legion will be upheld by Dominion Command. This person is not good for the Legion and has cost Branch 50 over \$50,000 in lost revenue.

Provincial Convention

The 2019 Provincial Convention is scheduled for August at Branch 12 in Grand Falls - Windsor, NL. This should be an interesting convention as Comrade Ross Petten has announced his intention to run for the Provincial President again. Also as the First Vice President position is currently being filled by the Second Vice President, the top three positions are open.

Membership

Like many other Provinces across Canada, NL Command continues to seek ways to improve membership. All Branches within this Command are striving to increase their membership numbers by trying to recruit while strongly encouraging present members to renew. We will continue to move forward and try to find better ways to improve our membership by targeting experienced active and retired military personnel and others regardless of background, age or profession.

VSS (Support to Veterans)

A Legion Action Committee is operating effectively at all three VAC Long Term Care contracted facilities within the province, St John's, Botwood and Corner Brook. The well-being of Veterans is of the utmost importance. A very competent and caring staff ensures all requirements are met for each Veteran.

All Branches continue to support the Pavilion in their area by attending Remembrance ceremonies and visiting the Veterans throughout the year. They also serve on committees at the respective Pavilions to assist the staff with the planning and coordination of events for the Veterans.

Provincial Command Service Officer

Data for 2018:

1. First Applications completed categorized by:
 - Still serving (1)
 - Retired (27)
 - RCMP (0)
2. Departmental Reviews (2)
3. VRAB Reviews (2)
4. VRAB Appeals and RFRs (Dominion Command) (2)
5. Number of Veterans counselled out/claims withdrawn (5)
6. Information and SCAN Seminars conducted (0)
7. Field visits to Branches (number of branches) (9)
8. VIP Applications submitted or WI for VIP (3)
9. Poppy Trust Fund Assistance provided in 2018 to the sum of \$47,055 from Provincial Command only.

Branch Service Officer training was held at Branch 12 in Grand Falls/Winsor on 20 October 2018. There were 29 of 45 Branches from across the Province represented at this training.

The Provincial Service Officer attended the Service Officer Professional Development in Charlottetown, PE.

The Eastern Region Service Officer Professional Development will be held in Montreal, QC in September 2019 and both the Provincial Service Officer and the Assistant Provincial Service Officer plan on attending.

2018 Provincial Command Pilgrimage to Europe

The July 2018 Pilgrimage / Tour of the Caribou was yet another very successful one. In speaking to the participants of the Pilgrimage many called it "a trip of a lifetime", "an emotional rollercoaster", "a great experience", "a very enjoyable trip" and "an amazing trip to have been on" were but a few of the comments. Each and every person were moved, humbled and extremely honoured to participate.

The Royal Canadian Legion, Newfoundland Labrador Command has worked with Veterans Affairs Canada to standardize the format for the ceremony held at Beaumont-Hamel. This was initiated by Newfoundland Labrador Command due to inconsistencies in protocol and previous plans discussed between the two prior to departure. We are

pleased that the Parks Canada staff at the Beaumont-Hamel have agreed to the new ceremony and last year's was very successful.

In conclusion, there was a full service at each of the monuments and partial services at most cemeteries that we visited. All Legion members, veterans and students took part by a reading, a prayer and singing the Ode to Newfoundland and O Canada. Our bugler played the last post at each venue and is to be commended for doing so. All tour members had the opportunity to be involved in some way - which made it very special and meaningful to all.

Youth Track & Field

The event began on Friday, 13 July 18 and continued Saturday, 14 July 18 with opening ceremonies. We had Mount Pearl Councillor Isabelle Fry in attendance to bring greetings. Approximately 30 young people from across the province participated in the Track & Field competition in Mount Pearl on 13/14 July 18. All athletes were extremely competitive and maintained high enthusiasm throughout the Provincial Meet. Medals were presented at the end of the competition by the President of NL Command, Berkley Lawrence.

In preparations for the national Track and Field competition, the Coaches selected to travel to Brandon, Manitoba, were Rosemary Ryan and Mark Miller along with Chaperones Donna and Nathan Lehr. 17 athletes were selected to represent Newfoundland and Labrador in Brandon, Manitoba from 8-14 August 18. Over the years, the legion has reached out in many ways to encourage our youth to carry the torch to remember our veterans. This is another avenue that we can avail of to keep our youth interested and educated in the legion, as well, future members of the legion.

The athletes were all proud to represent our Province and our Veterans.

Poppy and Remembrance Committee Report

The Poppy Campaign was started again this year with the presentation of the first poppy to Lieutenant Governor, Judy Foote and His Honour Howard Foote at Government House. We then proceeded to Confederation Building and performed the Fly the Flag of Remembrance ceremony.

Poster and Literary Contest We met in January to screen all the poster and literary contest submissions. All entries were then passed to the applicable judges and once the judging was completed, Brenda mailed the first place entries to Dominion Command for further judging. There were very little problems with the contest this year. The number of rejected entries was very low and this made the members of the committee very pleased. One major Branch did not get their entries in on time for the Provincial judging and I mention this because this is the Branch that Command has placed the Board of Trustees.

2019 Beaumont Hamel Pilgrimage We have identified the winning students from the contest that will be offered the Pilgrimage and hopefully we will have a positive response

from all. The selection committee has met and completed the selection of Veterans and Chaperones to attend. Details have been sent to all participants and the preparations for the Pilgrimage are well under way.

Education Committee

This committee consists of Berkley Lawrence and Leslie Forward. The Committee is responsible for reviewing all applications for the Provincial Bursaries (16) and to select the recipients in each category. Newfoundland and Labrador Provincial Command gives 1 bursary of \$1000 to first year students and 1 bursary of \$1000 to second and subsequent year students. The criteria for each bursary is basically the same, the student must be the son/daughter, grandson/granddaughter or great grandson/great granddaughter of a **veteran**. They must be enrolled in a university or college program and they must provide their last year's marks, letter of acceptance in a program and financial status.

The Bursary winners for 2018 are:

Provincial Bursary First year student - \$1000.00:

Tyra Dawe, Branch 5

Provincial Bursary Second year student - \$1000.00:

Elanor Dillabough, Branch 37

Remembrance Day

We had thousands out across the province to honour our fallen. Every branch we have spoken to reports continued strong numbers attending memorials and cenotaphs all across Newfoundland and Labrador. As always, Provincial Command coordinated events in St John's at the Sergeants' Memorial, the Peacekeepers Memorial and the Newfoundland and Labrador National War Memorial.

Bells of Peace

This event was a great success, starting in St. John's at our National War Memorial. The Provincial President was joined by the Lt Governor, the Mayor of St. John's, many Federal, Provincial and Municipal Government representatives for the ringing of the bells, a 17 gun salute and the playing of Amazing Grace by Comrade Gord Parsons (a veteran and a Branch President). There were many children also present. There were many ceremonies all across the Province and all reports were that all were very successful.

Remembrance Activities Master Schedule

There were a wide variety of Remembrance events around the province during the Remembrance period leading up to November 11th. They included but were not limited to, Fly the Flag of Remembrance Ceremony at Confederation Building in the Province's

Capital, school visitations and Remembrance Day services all over the province.

Lest We Forget - Military Service Recognition Book

We have published Volume 18 in our series of Military Service Recognition books. This project was once again successful from both a financial and community perspective. We continue to get support from Veterans and their families regarding the submissions of photos and information to go with them. We currently have numerous photos to be published in the next edition.

Social Media / Email Management

We currently have a web site, twitter and Facebook accounts for NL Command and publish information on them from time to time for our Branches and the general public.

Conclusion – President NL Command

I feel good about The Royal Canadian Legion NL Command, which is a professional team made up of our PEC, Provincial Chairs, Command Staff, and the 45 Branches throughout Newfoundland and Labrador. These are changing times and I feel confident with the people and support around me in Newfoundland and Labrador Command.

Berkley Lawrence
President
The Royal Canadian Legion
Newfoundland Labrador Command

Cockrell House Update

I offer a brief report on the Ministers' visit:

When I received a call from Ann Bolger (Senior Advisor, Veterans Priority Programs with VAC in Charlottetown) I agreed to set up a meeting for the Honourable Jody Wilson-Raybould, Minister of Veterans Affairs, accompanied by Deputy Minister General (ret'd) Walter Natynczyk to visit Cockrell House. As there is no common area in the house we met in the boardroom at my branch.

Attending the meeting were two others from Ottawa, plus two local VAC personnel for this region, our Cockrell House VAC case worker, our resident manager Rick Nicholson, myself, our Cockrell House secretary and three of our graduates :

- Denys Melanson
- Jason Mann
- John Vesallo

After introductions, I extended greetings from Command President Tom Irvine and National Director Brad White.

I then gave a brief overview of the project – our history, how and why we began 11 years ago – services that are offered to the veteran when he/she enters , numbers of vets we have been able to help successfully transition back into society and how we have , without government funding, been able to survive and help over 100 homeless veterans. Without the support Of the Royal Canadian Legion it would not have been possible.

I then asked our three alumni if they could address the Minister and share some of their experiences. This segment formed the bulk of the meeting.

I was very proud of all three of them, they spoke well and definitely caught the Ministers' attention. Even the Deputy was writing a lot of notes – and he has been here twice before.

I feel that personalizing the issue, putting faces to numbers, has a powerful impact.

In closing I spoke of the absolute need for this program, it must grow, it must expand, the need is great. We have proven that it works, can save lives. Our daily struggle is funding – NONE from any level of government.

It was a rush to put this together in just over 48 hours, but all agreed, worthwhile.

The meeting was scheduled for one hour but ran on for an hour and 35 minutes.

Respectfully

Angus

**Trip Report
Aboriginal First Nations
Calgary, Alberta
27 March 2019**

I must admit it was a pleasure attending my first meeting of the AFN.

I arrived in Calgary on the 26th and got the lay of the land in around the hotel as the meeting the next day was being held in the hotel. It was somewhat humorous as I met several people going to the same meeting as I was and they all had different timings for the next day.

We got that all sorted out in the morning and the meeting began. I think they were somewhat surprised at my arrival and plan to stay for the whole meeting because there was no place for me to sit and I was told I wasn't on till later. Once they realized that I was staying that pleased them all and a chair was quickly set up and I sat amongst them. They were pleased because no one usually stays for their meetings and I stated that I was there to learn from them and see how they do business.

The meeting was chaired by Regional Chief Norman Yakeleya and beside him was Grand Chief Steven Ross and Larry Whiteduck.

The meeting began with a roundtable, with all the regional chiefs from BC, ALB. AND SASK. Introducing themselves and telling their stories of where they were from and their heritage, along with their personal struggles growing up.

The agenda was full with subjects ranging from First Nations Housing to Cannabis use amongst veterans to creating a National First Nations Council. The sad part was everyone in the room had stories on each subject but no real solutions were discussed.

I spoke for about an hour to the gathering of about 20 Chiefs, Regional Chiefs and at least one elder while I was there answering questions to the council. Questions were asked about the language spoken at the national ceremony, treatment of native veterans in legion branches in the past and today. We also spoke on why the younger members of CAF were not joining the legion.

I can honestly say that they were very pleased at my attendance at this meeting and a couple of small issues were iron out. At the end of the presentation the gave me a small gift of appreciation and I gave each member of the head table one of my coins.

It is my recommendation that we continue to send representatives from DEC to attend these conferences as it strengthens our relationship with our aboriginal veterans and the First Nations community.

Thomas D. Irvine
Dominion President
1 April 2019

ITEM 15: CHARTERS ISSUES AND CANCELLED

The tables below represent the number of branches and Ladies' Auxiliaries which surrendered their charter in 2018.

The Royal Canadian Legion Cancelled Charters 2017				
Command	Closed Branch #	Destination Branch	Date of Cancellation	Surrendered or Revoked
ALTA-NWT	007		14 Dec. 2018	
Saskatchewan	11		5 May 2018	S
	205		5 May 2018	S
Manitoba & NWO	157		21 Apr. 2018	S
	232		21 Apr. 2018	S
	220		31 Dec. 2018	S
Ontario	195		15 Feb. 2018	S
Quebec	28		16 May. 2018	S
	228		3 Dec. 2018	S
Nova Scotia/Nunavut	117		13 Dec. 2018	S
Eastern Zone	17-001		21 April 2018	S
	17-096		21 April 2018	S

The Royal Canadian Legion New Charters 2018		
Command	Branch Number	DATE

For comparison to 2017:

Year	Surrendered	Revoked	New	Reinstated
2017	13	0	0	0
2018	12	0	0	0

The Royal Canadian Legion Amalgamated Charters 2017		
Command	Branch Number	DATE

Ladies' Auxiliary Cancelled Charters 2018		

Command	Closed Branch #	Destination Branch #	Date of Cancellation	Surrendered or Revoked
ALTA-NWT	003		9 Jan. 2018	S
	238		9 Jan. 2018	S
	184		30 Jan.2018	S
Manitoba & NWO	232		21 Apr. 2018	S
	173		4 May 2018	S
Ontario	077		31 July 2018	

For comparison to 2017:

Year	Surrendered	Revoked	New	Reinstated
2017	11	0	0	0
2018	6	0	0	0

ITEM 16: DOMINION COMMAND BRANCHES

a. Dominion Ottawa Branch 13-013

The following is the membership status of the Dominion Command Branch 13-013 as of 31, January 2019:

Category	2017	2018
Life	8	9
Ordinary	701	1099
Associate	583	1089
Affiliate Voting	216	294
Affiliate Non-Voting	34	57
Total	1542	2548

Online membership grew 65% year over year and continues to expand thanks to the added awareness of the Legion and the success of our member services website. Although recent growth has been impressive, total online memberships represented only 1.0% of 2018 total Legion membership.

b. Retired Military Members at Large – One-year Free Membership 16-015

	2017	2018
Total Members	353	215
New Members	240	211

Retired Military Members at Large declined during 2018 however; during our 2018 Dominion Convention delegates approved a free 1-year membership to all serving or retired CF members who are new to the Legion. Early in 2019, this branch already has over 1,400 members.

All Dominion Command branch members receive 3 renewal email reminders and one direct mail piece between November and April to encourage the continuance of their membership. All members are encouraged to transfer their memberships to a traditional branch in order to improve member retention.

c. Current Membership Fee

Current membership fees for Branch 13-013 are \$49.99 and no fee increase is foreseen at this time.

ITEM 18: MEETINGS AND INVITATIONS

2019

19-22 April	Easter Weekend – Legion House Closed
26–29 April	Dominion Cribbage – Branch 480 Ottawa, ON (Taha Cheng)
3–6 May	Dominion Darts – Branch 78 Dominion, NS (Crowe)
4-7 May	ON Command Provincial Convention – Niagara Falls, ON (Julian)
10-12 May	AB-NT Command Provincial Convention – Drumheller, AB (Flannigan)
18-19 May	QC Command Provincial Convention – Greenfield Park , QC (Parkhouse)
18-20 May	NS/NU Command Provincial Convention –Windsor, NS (Weaver)
22 May	VSS Committee Teleconference (1330 hrs EST)
24-25 May	PE Command Provincial Convention – Cornwall, PE (Chafe)
24–27 May	Dominion Eight Ball –Branch 4 Fredericton, NB (Flannigan)
15-16 June	MB & NWO Command Provincial Convention – Fort Frances, ON (Stanfield)
18-20 June	VRAB Hearings (Victory Boardroom)
TBD – July	Pilgrimage of Remembrance
9-11 August	2019 Legion National Youth Track & Field Championships, Cape Breton, NS
23-29 August	American Legion Convention – Indianapolis, IN (Julian)
24-28 August	NL Command Provincial Convention – Grand Falls Windsor, NL (Irvine)
9 September	National Rem. Day Ceremony Planning Meeting (1400 hrs –Victory Boardroom)
10-12 September	Eastern Regional Command Service Officer Seminar – Montreal, QC
13 September	Pay Committee (1400 hrs – Memorial Boardroom)
14 September	SEO Budget Committee (0900 hrs – Victory Boardroom)
19 September	VSS Committee Teleconference (1330 hrs EST)
21-23 September	NB Command Provincial Convention – Shediac, NB (Barham)
24-26 September	VRAB Hearings (Victory Boardroom)
26-29 September	BC/YT Command Provincial Convention – Penticton, BC (Irvine)
19-20 October	SK Command Provincial Convention – Moose Jaw, SK (Julian)
21-23 October	CIMBRH Forum 2019 – Lac Leamy Gatineau, QC (Irvine, Murray, McInnis)
11 November	Remembrance Day
18 November	National Rem. Day Post Ceremony Mtg (1400 hrs – Victory Boardroom)
22 November	Dominion President’s Christmas Reception (1300 hrs – Victory Boardroom)
22 November	RCEL Committee Meeting (TBD – Memorial Boardroom)
23 November	Committee Meetings TBD
24 November	DEC Committee Meeting (0900 hrs – Victory Boardroom)

2020

24-27 April	Dominion Cribbage – Branch 50 Conception Bay, NL (Weaver)
1-4 May	Dominion Darts – Branch 60 Burlington, ON (Lava)
29 May – 1 June	Dominion Eight Ball – Branch 104 Innisfail, AB (Andrews)
25-30 October	SOPD – Charlottetown, PE
26 October	RCL-Vac Bilateral, Charlottetown, PE



LIBERTY
CONCERT
NORMANDY



STARTING-
EVENT
TERNEUZEN



75 YEAR
FREEDOM
PROGRAM
LIMBURG



PROGRAM
BRABANT &
GELDERLAND



ZEELAND
PROGRAM
75 YEAR
BATTLE OF THE
SCHELDT



NATIONAL
TAPTOE



AUSCHWITZ
REMEMBRANCE

NATIONAL
HOLOCAUST
REMEMBRANCE



75 YEAR
REMEMBRANCES

OPERATION
VERITABLE

75 YEAR
D-DAY

6 June
2019

NATIONAL
START
CELEBRATION
75 YEAR
FREEDOM
31 Aug
2019

75 YEAR
FREEDOM
LIMBURG
12-14 Sept
2019

75 YEAR
OPERATION
MARKET
GARDEN
September
2019

BATTLE OF
THE SCHELDT
Oct/Nov
2019

NATIONAL
TAPTOE

January
2020

February
2020

75 YEARS
OF FREEDOM

44
EUROPE
REMEMBERS



75 YEAER
LIBERATION
OVERIJSEL,
DRENTHE,
FRIESLAND &
GRONINGEN



FREEDOM
MONTH



April
2020

REMEMBER



NATIONAL
REMEMBRANCE
DAY

4 May
2020

BEVRIJDINGSFESTIVAL 75
CELEBRATE



NATIONAL
LIBERATION
DAY

5 May
2020

MEMORIAL DAY



MARGRATEN

May
2020

INVICTUS
GAMES



ROTTERDAM
DEN HAAG

June
2020

NATIONAL
NDIË-
REMEMBRANCE
& CONCERT
DEN HAAG



REMEMBRANCE
END WOZ

15 August
2020

75 YEAR
UNITED
NATIONS



DEN HAAG

October
2020

**75 YEARS
OF FREEDOM**

**EUROPE
REMEMBERS**



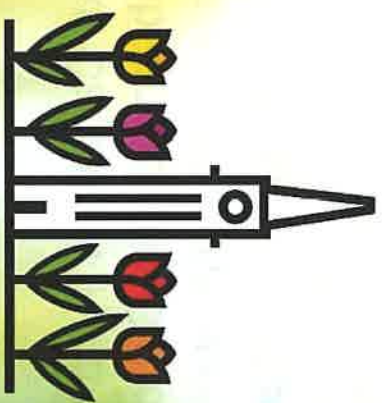

CANADIAN TULIP FESTIVAL
FESTIVAL CANADIEN DES TULIPES

YOUR Canadian Tulip Festival
A Celebration of the Gift of Tulips and Canada's Role
in the Liberation of the Netherlands in WWII





Our Focus, Re-Rooted

Celebrate & Remember



A poignant and pivotal moment in time, the Liberation of the Netherlands led by Canadian Forces, forged a friendship that has lasted over 74 years.

We honour the sacrifice of brave soldiers, our parents, grandparents and great-grandparents, by keeping their memory alive.

As Canadian Tulip Festival Founder, Malak Karsh, observed, the Gift of Tulips brought “colour back into a very gray world”. We celebrate this gift, the spirit of spring renewal.



tulipfestival.ca | festivaldestulipes.ca | Canada





LIBÉRATION

1945 - 2020



Liberation75



A National Commemorative Planting Campaign taking place this Fall 2019 spreading 1.1 Million **Orange** "Liberation75" Tulips across the country, ready to bloom in Spring 2020, in honour of the 1.1 Million Canadian Soldiers who served in WWII.

The Canadian Tulip Festival is proposing a portion of sales (\$1 per bag of 15 bulbs) will be donated to the Royal Canadian Legion.



tulipfestival.ca | festivaldestulipes.ca |





Liberation75

A Full Year Campaign



The Liberation75 Campaign runs from **May of 2019 through May of 2020**. Beginning with Pre-Sales at the Canadian Tulip Festival, **May 10, 2019**, and ramping up to an Online Campaign from **Labour Day to Remembrance Day**.

The Campaign continues into spring, when 1.1 Million Tulips Bloom and we celebrate our success at the Canadian Tulip Festival, **May 8 - 18, 2020**.



tulipfestival.ca | festivaldestulipes.ca |    



Liberation75

Repeating the Royal Gift

The Embassy of the Kingdom of the Netherlands is looking into repeating of The Dutch Royal Family gift to Canada, agreeing to purchase 100,000 “Liberation75” tulip bulbs. (“The Royal Bulbs”)



tulipfestival.ca | festivaldestulipes.ca





Liberation75

Sharing the Royal Gift

In collaboration with the Embassy of the Kingdom of the Netherlands the **100,000 “Royal” Liberation75 Bulbs** will be distributed to **1,100** schools across Canada.

These will be delivered with an educational program for both elementary and high school levels.



tulipfestival.ca | festivaldestulipes.ca | Canada





Liberation75

Online Sales, Fulfillment & Shipping

Sales to the public will be done online through a dedicated website and secure payment gateway.

Fulfillment will be done through our Bulb Supplier, DeVroomen, from their Niagara Falls centre. Shipping ideally will be done through Canada Post.



LIBÉRATIO
1945 - 2020
75



tulipfestival.ca | festivaldestulipes.ca |    

\$15.00/bag
Includes 15 bulbs

15,00 \$ / sac
Comprend 15 bulbes



LIBÉRATION
1945 - 2020



The Liberation75 Commemorative Partridge Campaign is made possible by:
Le campagne de rétribution commémorative Libération75 est rendue possible par:



With support from:  Avec le soutien de:              

Liberation75

A Special Offer

The Canadian Tulip Festival is in negotiations to be able to provide a Special Offer from Canada Post of **FREE SHIPPING on orders of 75 Bulbs (6 Bags)**.

The Royal Canadian Legion's Logo will be displayed on the "Liberation75" Tulip Bulb packaging, distributed nationwide.



    tulipfestival.ca | festivaldestulipes.ca |     



Liberation75 in The Netherlands*

DeVroomen will be matching the
Liberation75 Commemorative Planting
Campaign in the Netherlands.

DeVroomen will be marketing & selling 1.1
Million “Liberation75” Bulbs,
offering \$1 a bag to the Royal
Canadian Legion, and an
additional \$1 a bag to the
Canadian Tulip Festival.

*Currently in Negotiations





Liberation75

Growing our Network...

Having the support of the Royal Canadian Legion in spreading the “Liberation75” message to Legion members across Canada will help ensure we spread our message, and reach our goal of 1.1.Million “Liberation75” Tulips blooming across Canada in 2020.



LIBÉRATION
1945 - 2020
75



tulipfestival.ca | festivaldestulipes.ca |    

Thank you



CANADIAN TULIP FESTIVAL
FESTIVAL CANADIEN DES TULIPES

“Friends of the Legion”

A New Way to Generate Revenue

- The Legion National Foundation 
- Easy to Implement & Execute Immediately
- Inexpensive with Prospect for Excellent Returns
- It's Quite Simply a Cunning Plan

Comrade Owen Parkhouse

Friends of the Legion

- 3 Categories of Friendship
 - Gold, Silver & Bronze
 - \$5000.00, \$2500.00, \$1,000.00
- Not a Member of the Legion, but, a 'Friend'
 - No Commitment, No Expectations
- Foundation Advantage – Tax Receipt
 - Money Talks!



Friends of the Legion

- A Number of Organizations Have Variation on a Theme
 - Designed for the Well-Heeled
- Legion Badge Lapel Pin with Corresponding G,S,B
- Legion Magazine? Canvet Please!
- Going Forward Committee 'Get 'er Done'



Thank you – Questions and/or Comments

